

PAPER

## Non-expanding Plebański–Demiański space-times

To cite this article: J Podolský *et al* 2018 *Class. Quantum Grav.* **35** 165011

View the [article online](#) for updates and enhancements.



**IOP** Astronomy ebooks

Part of your publishing universe and your first choice for astronomy, astrophysics, solar physics and planetary science ebooks.

[iopscience.org/books/aas](http://iopscience.org/books/aas)

# Non-expanding Plebański–Demiański space-times

J Podolský<sup>1</sup>, O Hruška<sup>1</sup> and J B Griffiths<sup>2</sup>

<sup>1</sup> Institute of Theoretical Physics, Charles University, Prague, V Holešovičkách 2, 18000 Prague 8, Czechia

E-mail: [podolsky@mbox.troja.mff.cuni.cz](mailto:podolsky@mbox.troja.mff.cuni.cz), [HruskaOndrej@seznam.cz](mailto:HruskaOndrej@seznam.cz) and [j.b.griffiths@icloud.com](mailto:j.b.griffiths@icloud.com)

Received 5 April 2018, revised 16 June 2018

Accepted for publication 20 June 2018

Published 20 July 2018



CrossMark

## Abstract

The aim of this work is to describe the complete family of non-expanding Plebański–Demiański type D space-times and to present their possible interpretation. We explicitly express the most general form of such (electro) vacuum solutions with any cosmological constant, and we investigate the geometrical and physical meaning of the seven parameters they contain. We present various metric forms, and by analyzing the corresponding coordinates in the weak-field limit we elucidate the global structure of these space-times, such as the character of possible singularities. We also demonstrate that members of this family can be understood as generalizations of classic *B*-metrics. In particular, the *BI*-metric represents an external gravitational field of a tachyonic (superluminal) source, complementary to the *AI*-metric which is the well-known Schwarzschild solution for exact gravitational field of a static (standing) source.

Keywords: Plebański–Demiański, physical interpretation, B-metrics, cosmological constant, tachyonic source, exact space-times

(Some figures may appear in colour only in the online journal)

## 1. Introduction

The famous class of Plebański–Demiański space-times is the most general family of exact solutions of the Einstein(–Maxwell) equations with any value of the cosmological constant  $\Lambda$ , whose gravitational fields are of algebraic type D and electromagnetic fields are doubly aligned. The class includes two distinct families according to whether or not the repeated principal null directions are expanding. In the *expanding case* they involve nine distinct parameters, and

<sup>2</sup> Retired.

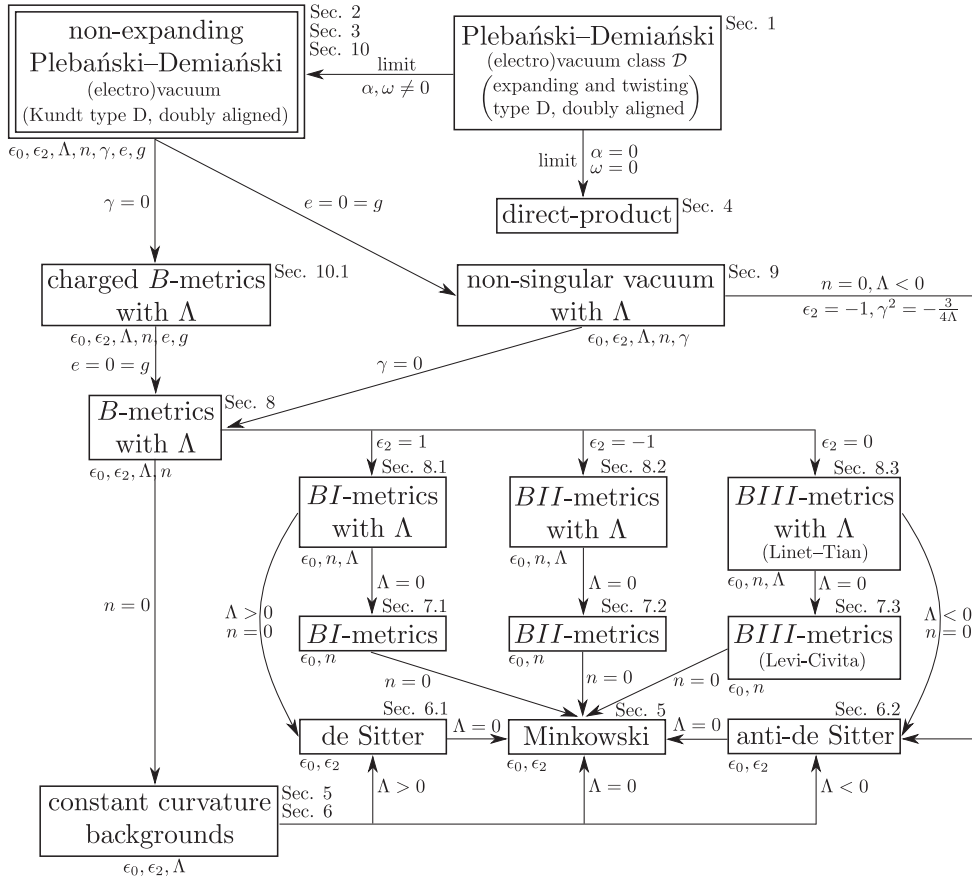

**Figure 1.** Schematic diagram of the structure of the complete family of non-expanding Plebański–Demiański space-times. These are (electro)vacuum solutions of the Einstein(–Maxwell) equations with any cosmological constant  $\Lambda$  (and aligned electromagnetic field). All solutions belong to the Kundt class, and their gravitational field is of algebraic type D. By setting any of the seven independent parameters  $\epsilon_0$ ,  $\epsilon_2$ ,  $\Lambda$ ,  $n$ ,  $\gamma$ ,  $e$ ,  $g$  to zero, various specific subfamilies are obtained, such as the  $B$ -metrics and background spaces of constant curvature (Minkowski, de Sitter, anti-de Sitter). Each of these subfamilies is analyzed in a specific section of this contribution, as also indicated in the diagram.

include a family of generalized black hole space-times. In the *non-expanding case*, however, there are fewer parameters. We will show in sections 1–4 that the complete family of such solutions involves seven parameters, namely  $\epsilon_0$ ,  $\epsilon_2$ ,  $\Lambda$ ,  $n$ ,  $\gamma$ ,  $e$ , and  $g$ . The geometrical and/or physical meaning of these parameters will be clarified in sections 5–10. Moreover, by setting any of these parameters to zero, specific subfamilies are directly obtained, namely the  $B$ -metrics and their generalizations to include the cosmological constant and an aligned electromagnetic field. A diagram summarizing all these subfamilies and their mutual relations is presented in figure 1.

The complete class of the Plebański–Demiański solutions [1] can be conveniently expressed in terms of the line element [2, 3]

$$ds^2 = \frac{1}{(1 - \alpha pr)^2} \left[ -\frac{\mathcal{Q}^e}{r^2 + \omega^2 p^2} (d\tau - \omega p^2 d\sigma)^2 + \frac{r^2 + \omega^2 p^2}{\mathcal{Q}^e} dr^2 + \frac{\mathcal{P}^e}{r^2 + \omega^2 p^2} (\omega d\tau + r^2 d\sigma)^2 + \frac{r^2 + \omega^2 p^2}{\mathcal{P}^e} dp^2 \right], \quad (1)$$

where

$$\begin{aligned} \mathcal{P}^e(p) &= k + 2n\omega^{-1}p - \epsilon p^2 + 2\alpha mp^3 - \left( \alpha^2(\omega^2 k + e^2 + g^2) + \frac{1}{3}\omega^2 \Lambda \right) p^4, \\ \mathcal{Q}^e(r) &= (\omega^2 k + e^2 + g^2) - 2mr + \epsilon r^2 - 2\alpha n\omega^{-1}r^3 - \left( \alpha^2 k + \frac{1}{3}\Lambda \right) r^4, \end{aligned} \quad (2)$$

and  $m, n, e, g, \Lambda, \epsilon, k, \alpha, \omega$  are arbitrary real parameters. This metric represents type D solutions for which the repeated principal null directions are *shear-free*, *expanding* and *twisting*. Indeed, adopting the null tetrad

$$\begin{aligned} \mathbf{k} &= \frac{1 - \alpha pr}{\sqrt{2(r^2 + \omega^2 p^2)}} \left[ \frac{1}{\sqrt{\mathcal{Q}^e}} (r^2 \partial_\tau - \omega \partial_\sigma) - \sqrt{\mathcal{Q}^e} \partial_r \right], \\ \mathbf{l} &= \frac{1 - \alpha pr}{\sqrt{2(r^2 + \omega^2 p^2)}} \left[ \frac{1}{\sqrt{\mathcal{Q}^e}} (r^2 \partial_\tau - \omega \partial_\sigma) + \sqrt{\mathcal{Q}^e} \partial_r \right], \\ \mathbf{m} &= \frac{1 - \alpha pr}{\sqrt{2(r^2 + \omega^2 p^2)}} \left[ -\frac{1}{\sqrt{\mathcal{P}^e}} (\omega p^2 \partial_\tau + \partial_\sigma) + i \sqrt{\mathcal{P}^e} \partial_p \right], \end{aligned} \quad (3)$$

the spin coefficients are  $\kappa = 0 = \nu, \sigma = 0 = \lambda,$

$$\rho = \sqrt{\frac{\mathcal{Q}^e}{2(r^2 + \omega^2 p^2)}} \frac{1 + i\alpha\omega p^2}{r + i\omega p} = \mu, \quad (4)$$

and  $\tau = \pi, \epsilon = \gamma, \alpha = \beta$  are also non-zero. The congruences generated by  $\mathbf{k}$  and  $\mathbf{l}$  are thus geodesic and shear-free, but have non-zero expansion, and their twist is proportional to the parameter  $\omega$ . Using the tetrad (3), the only non-trivial Weyl NP scalar is

$$\Psi_2 = -(m + in) \left( \frac{1 - \alpha pr}{r + i\omega p} \right)^3 + (e^2 + g^2) \left( \frac{1 - \alpha pr}{r + i\omega p} \right)^3 \frac{1 + \alpha pr}{r - i\omega p}, \quad (5)$$

confirming that these space-times are of algebraic type D with the repeated principal null directions  $\mathbf{k}$  and  $\mathbf{l}$ . Apart from  $\Lambda$ , the only non-zero Ricci NP scalar is

$$\Phi_{11} = \frac{1}{2} (e^2 + g^2) \frac{(1 - \alpha pr)^4}{(r^2 + \omega^2 p^2)^2}, \quad (6)$$

where  $e$  and  $g$  are the electric and magnetic charges of the source, respectively. Both principal null directions of the non-null electromagnetic field are thus aligned with the repeated principal null directions of the gravitational field. Clearly, there is a curvature singularity at  $r = 0 = \omega p$ . In general, this is surrounded by horizon(s) which are roots of the function  $\mathcal{Q}^e(r)$ . In fact, the expanding metric (1), (2) includes a *large family of black holes with various physical parameters*, such as the mass  $m$ , Kerr-like rotation  $a$ , NUT parameter  $l$  (related to the twist parameter  $\omega$  and  $n$ ), cosmological constant  $\Lambda$ , electromagnetic charges  $e, g$  and acceleration  $\alpha$ , see [2, 3] for more details.

Interestingly, *non-expanding Plebański–Demiański* type D space-times can be obtained from the line element (1), which represents expanding space-times, by applying specific ‘degenerate’ transformation. Apart from the exceptional case of direct-product geometries [2, 3], see section 4 below, the *general family* of such solutions is obtained by applying the transformation

$$r = \gamma + \kappa q, \quad \sigma = k_1 y + \omega \kappa^{-1} t, \quad \tau = k_2 y - \gamma^2 \kappa^{-1} t, \quad (7)$$

where  $\gamma$  and  $\kappa$  are arbitrary parameters, and taking the limit in which  $\kappa \rightarrow 0$ . In this limit the function  $\mathcal{Q}^e$  is *rescaled to zero* as  $\kappa^2 \mathcal{Q}$ , and the resulting line element takes the form

$$ds^2 = \frac{1}{(1 - \alpha\gamma p)^2} \left[ \varrho^2 \left( -\mathcal{Q} dt^2 + \frac{1}{\mathcal{Q}} dq^2 \right) + \frac{\mathcal{P}^e}{\varrho^2} \left( (k_1 \gamma^2 + k_2 \omega) dy + 2\gamma\omega q dt \right)^2 + \frac{\varrho^2}{\mathcal{P}^e} dp^2 \right], \quad (8)$$

where

$$\varrho^2 = \omega^2 p^2 + \gamma^2,$$

$$\mathcal{Q} = \epsilon_0 - \epsilon_2 q^2,$$

$$\mathcal{P}^e = k + 2n\omega^{-1}p - \epsilon p^2 + 2\alpha mp^3 - (\alpha^2(\omega^2 k + e^2 + g^2) + \frac{1}{3}\omega^2 \Lambda) p^4, \quad (9)$$

with an additional free constant  $\epsilon_0$  resulting from the limiting procedure ( $\epsilon_0 \approx \kappa^{-2} \mathcal{Q}^e$ , see section 7.1 of [2]), and

$$\epsilon = -\epsilon_2 + 6\alpha\gamma n\omega^{-1} + 2\gamma^2(3\alpha^2 k + \Lambda). \quad (10)$$

The parameters of these solutions must also satisfy two further constraints, namely

$$3m + \gamma(\epsilon_2 - 2\epsilon) + 3\alpha\gamma^2 n\omega^{-1} = 0, \quad (11)$$

$$\omega^2 k + e^2 + g^2 - \gamma m + \frac{1}{6}\gamma^2(\epsilon + \epsilon_2) = 0. \quad (12)$$

Apart from the exceptional case  $\omega = 0 = \gamma$ , it is always possible to choose the constants  $k_1$  and  $k_2$  in such a way that  $k_1 \gamma^2 + k_2 \omega = 1$ .

After the transformation (7) and the limit  $\kappa \rightarrow 0$  are performed, the null tetrad (3) for the metric (8), (9) becomes

$$\begin{aligned} \mathbf{k} &= \frac{1 - \alpha\gamma p}{\sqrt{2}\varrho} \left[ \frac{1}{\sqrt{\mathcal{Q}}} (2\omega\gamma q \partial_y - \partial_t) - \sqrt{\mathcal{Q}} \partial_q \right], \\ \mathbf{l} &= \frac{1 - \alpha\gamma p}{\sqrt{2}\varrho} \left[ \frac{1}{\sqrt{\mathcal{Q}}} (2\omega\gamma q \partial_y - \partial_t) + \sqrt{\mathcal{Q}} \partial_q \right], \\ \mathbf{m} &= \frac{1 - \alpha\gamma p}{\sqrt{2}} \left[ -\frac{\varrho}{\sqrt{\mathcal{P}^e}} \partial_y + i \frac{\sqrt{\mathcal{P}^e}}{\varrho} \partial_p \right], \end{aligned} \quad (13)$$

with (4) now taking the form  $\rho = 0 = \mu$  (because  $\mathcal{Q}^e = \kappa^2 \mathcal{Q} \rightarrow 0$ ). The double degenerate principal null directions  $\mathbf{k}$  and  $\mathbf{l}$  given by (13) are therefore *non-expanding* and *non-twisting*. The Weyl curvature (5) becomes

$$\Psi_2 = -(m + in) \left( \frac{1 - \alpha\gamma p}{\gamma + i\omega p} \right)^3 + (e^2 + g^2) \left( \frac{1 - \alpha\gamma p}{\gamma + i\omega p} \right)^2 \frac{1 - \alpha^2 \gamma^2 p^2}{\gamma^2 + \omega^2 p^2}, \quad (14)$$

while the Ricci curvature (6) now reads

$$\Phi_{11} = \frac{1}{2} (e^2 + g^2) \frac{(1 - \alpha\gamma p)^4}{(\gamma^2 + \omega^2 p^2)^2}. \quad (15)$$

Such solutions contain the *charge parameters*  $e$  and  $g$ , the *cosmological constant*  $\Lambda$  and *six additional parameters*  $\alpha, \omega, n, \gamma$  and  $\epsilon_0, \epsilon_2$  (entering  $\mathcal{Q}$ ). The parameters  $k, \epsilon, m$ , which also occur in  $\mathcal{P}^e$ , are uniquely determined by the constraints (10)–(12). Explicit elimination gives

$$\begin{aligned} k &= \frac{-(e^2 + g^2) - \epsilon_2 \gamma^2 + 2\alpha\gamma^3 n \omega^{-1} + \Lambda \gamma^4}{\omega^2 - 3\alpha^2 \gamma^4}, \\ \epsilon &= \frac{-\epsilon_2(\omega^2 + 3\alpha^2 \gamma^4) + 6\alpha\gamma(\omega^2 - \alpha^2 \gamma^4) n \omega^{-1} - 6\alpha^2 \gamma^2 (e^2 + g^2) + 2\Lambda \gamma^2 \omega^2}{\omega^2 - 3\alpha^2 \gamma^4}, \\ m &= \frac{-\epsilon_2 \gamma(\omega^2 + \alpha^2 \gamma^4) + \alpha \gamma^2 (3\omega^2 - \alpha^2 \gamma^4) n \omega^{-1} - 4\alpha^2 \gamma^3 (e^2 + g^2) + \frac{4}{3} \Lambda \gamma^3 \omega^2}{\omega^2 - 3\alpha^2 \gamma^4}. \end{aligned} \quad (16)$$

Now, it needs to be determined whether or not the six parameters  $\alpha, \omega, n, \gamma, \epsilon_0, \epsilon_2$  are independent, and then to determine their geometrical and/or physical meaning.

## 2. General solution: removing the parameters $\alpha$ and $\omega$

We will now show that the parameters  $\alpha$  and  $\omega$  in the metric (8), (9) are, in fact, *redundant*. It is immediately seen from (8)–(12) that  $\alpha$  plays no role whenever  $\gamma = 0$  (redefining  $\epsilon, m, k$ ). Moreover,  $\alpha$  can be explicitly transformed away for any value of  $\gamma$ , and  $\omega$  can be set to 1 (unless  $\omega = 0 = \alpha$ ), by applying the substitution

$$p = \frac{\tilde{p} - \alpha\gamma^3 \mu}{\omega^2 \mu + \alpha\gamma \tilde{p}}, \quad y = \frac{\tilde{y}}{\mu}, \quad \text{where } \mu^2 = \frac{1}{\omega^2 + \alpha^2 \gamma^4}. \quad (17)$$

Under this transformation, the metric (8) becomes

$$ds^2 = \tilde{q}^2 \left( -\tilde{\mathcal{Q}} dt^2 + \frac{1}{\tilde{\mathcal{Q}}} dq^2 \right) + \frac{\tilde{\mathcal{P}}}{\tilde{q}^2} \left( d\tilde{y} + 2\tilde{\gamma} q dt \right)^2 + \frac{\tilde{q}^2}{\tilde{p}} d\tilde{p}^2, \quad (18)$$

$$\tilde{q}^2 = \tilde{p}^2 + \tilde{\gamma}^2, \quad \tilde{\mathcal{Q}} = \epsilon_0 - \epsilon_2 q^2, \quad \tilde{\mathcal{P}} = a_0 + 2\tilde{n} \tilde{p} + a_2 \tilde{p}^2 - \frac{1}{3} \Lambda \tilde{p}^4, \quad (19)$$

where

$$\tilde{\mathcal{P}} = \mu^2 (\omega^2 \mu + \alpha\gamma \tilde{p})^4 \mathcal{P}^e, \quad \tilde{\gamma} = \gamma \omega \mu, \quad (20)$$

with

$$\begin{aligned} a_0 &= -(e^2 + g^2) - \epsilon_2 \tilde{\gamma}^2 + \Lambda \tilde{\gamma}^4, \quad a_2 = \epsilon_2 - 2\Lambda \tilde{\gamma}^2, \\ 2\tilde{n}/\mu &= -2\alpha\gamma^3 \frac{3\omega^2 - \alpha^2 \gamma^4}{\omega^2 - 3\alpha^2 \gamma^4} \epsilon_2 + 2 \frac{(\omega^2 + \alpha^2 \gamma^4)^2}{\omega^2 - 3\alpha^2 \gamma^4} \frac{n}{\omega} \\ &\quad - 4\alpha\gamma \frac{\omega^2 + \alpha^2 \gamma^4}{\omega^2 - 3\alpha^2 \gamma^4} (e^2 + g^2) + \frac{8\alpha\gamma^5 \omega^2 (3\omega^2 - \alpha^2 \gamma^4)}{3(\omega^2 + \alpha^2 \gamma^4)(\omega^2 - 3\alpha^2 \gamma^4)} \Lambda. \end{aligned}$$

By comparing to (8), (9), it can now be seen that the above transformation indeed explicitly sets  $\omega = 1$  and removes the parameter  $\alpha$  from the metric (after an appropriate relabelling of the parameters  $m, n, k$  and  $\epsilon$ ). This is analogous to the case an *apparently* accelerating NUT metric studied in [4] for which the acceleration parameter  $\alpha$  was similarly shown to be

redundant. In fact, the two transformations are remarkably similar (compare equation (17) with equation (22) in [4]).

Notice that (for  $e = 0 = g$ ) the parameter  $\alpha$  determines a kind of *formal rotation in the complex plane* spanned of the parameters  $m + in$ , yielding  $\tilde{m} + i\tilde{n}$ . This is clearly seen by performing the substitution (17) in the scalar  $\Psi_2$  given by (14):

$$\Psi_2 = -(m + in) \left( \frac{1 - \alpha\gamma p}{\gamma + i\omega p} \right)^3 = -c^{\frac{3}{2}} \frac{(m + in)}{(\tilde{\gamma} + i\tilde{p})^3}, \quad \text{where } c = \frac{\omega + i\alpha\gamma^2}{\omega - i\alpha\gamma^2}. \quad (21)$$

The parameter  $c$  depending on  $\omega$  and  $\alpha\gamma^2$  is clearly a *complex unit*. Setting  $\alpha = 0$  by (17) is thus accompanied by a re-parametrization  $\tilde{m} + i\tilde{n} = c^{\frac{3}{2}}(m + in)$ , i.e. mixing the ‘original’  $m$  and  $n$ .

To conclude: The Plebański–Demiański class of non-expanding (electro)vacuum space-times with a cosmological constant can be written, *without loss of generality*, by setting  $\alpha = 0$  and  $\omega = 1$  in the metric (8), (9) as

$$ds^2 = \varrho^2 \left( -\mathcal{Q} dt^2 + \frac{1}{\mathcal{Q}} dq^2 \right) + \frac{\mathcal{P}}{\varrho^2} \left( dy + 2\gamma q dt \right)^2 + \frac{\varrho^2}{\mathcal{P}} dp^2, \quad (22)$$

where, using (16) with  $\alpha = 0$ ,

$$\begin{aligned} \varrho^2 &= p^2 + \gamma^2, \\ \mathcal{Q}(q) &= \epsilon_0 - \epsilon_2 q^2, \\ \mathcal{P}(p) &= -(e^2 + g^2) - \epsilon_2 \gamma^2 + \Lambda \gamma^4 + 2np + (\epsilon_2 - 2\Lambda \gamma^2) p^2 - \frac{1}{3} \Lambda p^4. \end{aligned} \quad (23)$$

The non-zero curvature scalars are  $R = 4\Lambda$  and

$$\Psi_2 = \frac{\epsilon_2 \gamma - \frac{4}{3} \Lambda \gamma^3 - in}{(\gamma + ip)^3} + \frac{e^2 + g^2}{(p^2 + \gamma^2)(\gamma + ip)^2}, \quad \Phi_{11} = \frac{e^2 + g^2}{2(p^2 + \gamma^2)^2}. \quad (24)$$

This class of solutions contains *two discrete parameters*  $\epsilon_0$  and  $\epsilon_2$  (using the remaining scaling freedom in  $q$  and  $t$  they take the possible values  $+1, 0, -1$ ) and *five continuous parameters*  $n$ ,  $\gamma$  and  $e, g, \Lambda$ . Since  $e$  and  $g$  denote the electric and magnetic charges, respectively, and  $\Lambda$  is the cosmological constant, it remains to determine the geometrical meaning of the parameters  $\epsilon_0$  and  $\epsilon_2$  and the physical meaning of the parameters  $n$  and  $\gamma$ . This will be done in sections 5, 6 and 7–9, respectively. In the final section 10 we will discuss the complete family, including the charges  $e$  and  $g$ .

Let us mention that this class of solutions was first found (employing different notation for the coordinates and free parameters) in 1968 by Carter [5] as his family  $[\tilde{B}(-)]$ , see equations (12)–(15) therein. Subsequently, it was obtained and discussed as ‘generalized anti-NUT solution’ by Plebański, see pages 235–237 of [6], equations (3.35)–(3.40) of [7], and equations (8) and (9) of [8] by García Díaz and Plebański. The vacuum case with  $\Lambda = 0$  is also equivalent to the case IV of Kinnersley [9]. The relation between the Plebański–Demiański class of doubly aligned type D Einstein–Maxwell fields (denoted as  $\mathcal{D}$ ) and other algebraically special solutions has been thoroughly summarized in a recent work [10].

### 3. The canonical Kundt form of these space-times

Since these solutions admit an expansion-free, twist-free and shear-free repeated principal null direction of the Weyl tensor, they belong to the Kundt class. It must be possible to express them in the canonical Kundt form. For the case  $\alpha = 0$ , which is (as shown in previous section) general, this was explicitly already done in [3]. To put the metric (22), (23) into the Kundt form, first perform the transformation

$$z = p, \quad y_k = y + 2\gamma \int \frac{q}{Q} dq, \quad r = (p^2 + \gamma^2) q, \quad u = t - \int \frac{1}{Q} dq, \quad (25)$$

which takes the metric to

$$ds^2 = -2 du dr - 2H du^2 + 2W_{y_k} du dy_k + 2W_z du dz + \frac{1}{P^2} dy_k^2 + P^2 dz^2, \quad (26)$$

with

$$P^2 = \frac{(\gamma^2 + z^2)}{\mathcal{P}(z)},$$

$$H = \frac{\epsilon_0}{2}(\gamma^2 + z^2) - \frac{1}{(\gamma^2 + z^2)} \left[ \frac{\epsilon_2}{2} + \frac{2\gamma^2}{(\gamma^2 + z^2)P^2} \right] r^2,$$

$$W_{y_k} = \frac{2\gamma}{(\gamma^2 + z^2)P^2} r, \quad W_z = \frac{2z}{(\gamma^2 + z^2)} r.$$

Now, replace  $z = p$  by a new coordinate

$$x = \int P^2(z) dz, \quad (27)$$

which puts the metric to the Kundt (real) form

$$ds^2 = -2 du dr - 2H du^2 + 2W_x du dx + 2W_{y_k} du dy_k + P^{-2}(dx^2 + dy_k^2), \quad (28)$$

where

$$W_x = \frac{2z}{(\gamma^2 + z^2)P^2} r, \quad W_{y_k} = \frac{2\gamma}{(\gamma^2 + z^2)P^2} r,$$

and all metric functions must be re-expressed as functions of  $x$  via  $z$ . It is of interest to note that all metric coefficients are independent of  $y_k$ . Thus, these space-times admit the *two Killing vectors*  $\partial_u$  and  $\partial_{y_k}$ . In view of this symmetry, the metric form (28) may be the most appropriate to use. Moreover, the presence of the spacelike Killing vector  $\partial_{y_k}$  indicates that these space-times could possess axial symmetry.

By putting  $\zeta = \frac{1}{\sqrt{2}}(x + i y_k)$ , the metric (28) is then easily expressed in the familiar canonical complex form

$$ds^2 = -2 du (dr + H du + W d\zeta + \bar{W} d\bar{\zeta}) + 2P^{-2}d\zeta d\bar{\zeta}, \quad (29)$$

where  $W \equiv -\frac{1}{\sqrt{2}}(W_x - i W_{y_k})$  reads

$$W = -\frac{\sqrt{2}}{(z + i\gamma)P^2} r, \quad (30)$$



in which  $z$  and  $P$  are functions of the *real part* of  $\zeta$  only, see (27). These expressions are equivalent to those given in section 18.6 of the monograph [3].

#### 4. Special case $\alpha = 0$ , $\omega = 0$ : direct-product geometries

In this particular case it is possible to apply on (1) with  $\tilde{n} \equiv n\omega^{-1}$  a transformation

$$p = \beta + \kappa \tilde{p}, \quad r = \gamma + \kappa \tilde{q}, \quad \sigma = \kappa^{-1} \tilde{\sigma}, \quad \tau = b^2 \kappa^{-1} \tilde{\tau}, \quad (31)$$

which yields

$$ds^2 = -\frac{b^4 \tilde{Q}}{(\gamma + \kappa \tilde{q})^2} d\tilde{\tau}^2 + (\gamma + \kappa \tilde{q})^2 \left( \frac{1}{\tilde{Q}} d\tilde{q}^2 + \tilde{P} d\tilde{\sigma}^2 + \frac{1}{\tilde{P}} d\tilde{p}^2 \right), \quad (32)$$

with

$$\begin{aligned} \tilde{P} &= \kappa^{-2} \mathcal{P}^e = a_0 + a_1 \tilde{p} + a_2 \tilde{p}^2, \\ \tilde{Q} &= \kappa^{-2} \mathcal{Q}^e = b_0 + b_1 \tilde{q} + b_2 \tilde{q}^2, \end{aligned} \quad (33)$$

and

$$\begin{aligned} a_2 &= -\epsilon, & b_2 &= \epsilon - 2\Lambda \gamma^2, \\ a_1 &= 2\kappa^{-1}(\tilde{n} - \epsilon \beta), & b_1 &= 2\kappa^{-1}(-m + \epsilon \gamma - \frac{2}{3}\Lambda \gamma^3), \\ a_0 &= \kappa^{-2}(k + 2\beta \tilde{n} - \epsilon \beta^2), & b_0 &= \kappa^{-2}(e^2 + g^2 - 2m\gamma + \epsilon \gamma^2 - \frac{1}{3}\Lambda \gamma^4). \end{aligned} \quad (34)$$

A non-expanding solution is now obtained by performing the limit  $\kappa \rightarrow 0$ , giving

$$ds^2 = b^2 \left( -Y d\tilde{\tau}^2 + \frac{1}{Y} d\tilde{q}^2 \right) + \gamma^2 \left( X d\tilde{\sigma}^2 + \frac{1}{X} d\tilde{p}^2 \right), \quad (35)$$

where

$$X(\tilde{p}) = a_0 + a_1 \tilde{p} + a_2 \tilde{p}^2, \quad Y(\tilde{q}) = \frac{b^2}{\gamma^2} (b_0 + b_1 \tilde{q} + b_2 \tilde{q}^2). \quad (36)$$

This metric clearly represents the class of geometries which are the *direct-product of two 2-spaces of constant curvature* with signatures  $(-, +)$  and  $(+, +)$ . These are the algebraic type D or conformally flat, (electro)vacuum Bertotti–Robinson, Narai, and Plebański–Hacyan solutions (see chapter 7 in [3]).

To summarize: Starting from the Plebański–Demiański metric (1) with the parameters  $\alpha$  and  $\omega$  non-vanishing, the only possible non-expanding limit is the metric (22), (23). When  $\alpha = 0$  and  $\omega = 0$  a separate procedure leads to the well-known family of direct-product geometries (35), (36).

#### 5. The Minkowski background: $\Lambda, n, \gamma, e, g = 0$

To understand the geometrical meaning of the parameters  $\epsilon_0$  and  $\epsilon_2$ , which take the discrete values  $+1, 0, -1$ , we naturally investigate them in the ‘background’ situation when all the other five physical parameters are set to zero. In such a case it follows from (24) that the metric (22), (23) reduces just to *flat Minkowski space*.

### 5.1. Minkowski space in Plebański–Demiański coordinates

Let us consider the above family of solutions in the flat case in which the parameters  $\Lambda, n, \gamma$  and  $e, g$  are all set to zero. The metric (22) then becomes

$$ds^2 = p^2 \left( -\mathcal{Q} dt^2 + \frac{1}{\mathcal{Q}} dq^2 \right) + \epsilon_2 dy^2 + \frac{1}{\epsilon_2} dp^2, \quad (37)$$

where  $\mathcal{Q} = \epsilon_0 - \epsilon_2 q^2$ . To maintain the correct signature  $(-+++)$ , the parameter  $\epsilon_2$  must be positive and may be taken to be unity,  $\epsilon_2 = 1$ . The resulting form of Minkowski space

$$ds^2 = -p^2(\epsilon_0 - q^2) dt^2 + \frac{p^2}{\epsilon_0 - q^2} dq^2 + dy^2 + dp^2, \quad (38)$$

thus contain just a *single parameter*  $\epsilon_0$ , which may be taken to be  $\epsilon_0 = +1, 0, -1$ . Now we will discuss these three possibilities. They are three different choices of the  $t$ - $q$  coordinates (foliations) which do not change the curvature of the 2-dimensional Lorentzian subspace. Its Gaussian curvature is given by  $\epsilon_2 = 1$ .

**5.1.1. The case  $\epsilon_0 = +1$**  In this case the metric (38) has the form

$$ds^2 = -p^2(1 - q^2) dt^2 + \frac{p^2}{1 - q^2} dq^2 + dy^2 + dp^2. \quad (39)$$

There exist *Killing horizons* at  $q = \pm 1$  corresponding to the vector field  $\partial_t$ . Clearly,  $q$  is a spacelike coordinate and  $t$  is timelike when  $q \in (-1, 1)$ . Otherwise  $q$  is timelike and  $t$  spacelike.

- When  $|q| < 1$ , the metric (39) is static, and can be derived from the usual Cartesian coordinates of Minkowski space

$$ds^2 = -dT^2 + dX^2 + dY^2 + dZ^2 \quad (40)$$

using the transformation

$$\left. \begin{aligned} T &= \pm p \sqrt{1 - q^2} \sinh t, \\ X &= p q, \\ Y &= y, \\ Z &= \pm p \sqrt{1 - q^2} \cosh t, \end{aligned} \right\} \Rightarrow \left\{ \begin{aligned} p &= \sqrt{X^2 + Z^2 - T^2}, \\ q &= \frac{X}{\sqrt{X^2 + Z^2 - T^2}}, \\ \tanh t &= \frac{T}{Z}, \\ y &= Y, \end{aligned} \right. \quad (41)$$

where  $t, y \in (-\infty, \infty)$  and  $p \in [0, \infty)$ . Clearly, the surfaces  $p = \text{const.} \neq 0$  and  $q = \text{const.}$  are geometrically given by

$$-\frac{T^2}{p^2} + \frac{X^2}{p^2} + \frac{Z^2}{p^2} = 1 \quad \text{and} \quad \frac{q^2 - 1}{q^2} X^2 + Z^2 = T^2, \quad (42)$$

respectively. The character of these Plebański–Demiański coordinates is illustrated in figures 2 and 3. The form of the metric (39) is clearly *valid only in the region*  $Z^2 > T^2$  outside the pair of null hyperplanes on which  $Z^2 = T^2$  (that is  $t = \pm\infty$ ). The *coordinate singularity*  $p = 0$  for any finite  $t$  and  $q$  is just the  $Y$ -axis, namely  $T = 0, X = 0 = Z$ , with  $Y$  arbitrary, see the left part of expression (41). (We cannot use the inverse relation on the

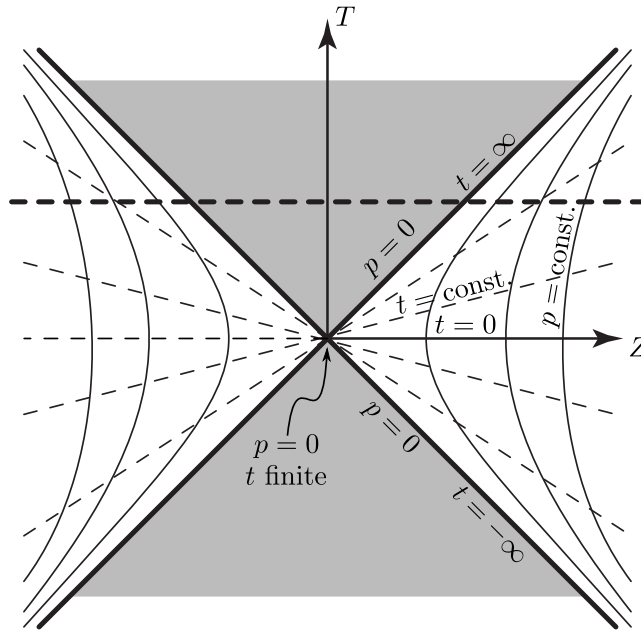

**Figure 2.** A section of the background flat space on which  $X = 0$  (corresponding to  $q = 0$ ) and  $Y = y$  is any constant. For all three Plebański–Demiański coordinate parameterisations of Minkowski space with  $\epsilon_0 = +1, 0, -1$ , the surfaces on which  $p > 0$  is a constant are *rotational hyperboloids*  $-T^2 + X^2 + Z^2 = p^2$  around the expanding (for  $T > 0$ ) or contracting (for  $T < 0$ ) cylinder  $X^2 + Z^2 = T^2$ ,  $Y$  arbitrary. The coordinate singularity  $p = 0$  is located along the  $Y$ -axis ( $T = 0$ ,  $X = 0 = Z$ ,  $Y$  arbitrary). The surfaces on which  $t$  is constant are *planes* through the spacelike line on which  $T = 0 = Z$ , with  $X, Y$  arbitrary. The horizontal heavy dashed line indicates the section  $T = \text{const.}$  through the space-time that is illustrated in figure 3. The shaded regions are not covered by the Plebański–Demiański coordinates.

right part of (41) since the Jacobian of the transformation is  $|J| = p^2$ , i.e. the transformation is not regular at  $p = 0$ .)

The *Killing horizons* at  $q = \pm 1$  correspond to the two parts of the null planes  $T = \pm Z$  with  $X < 0$  for  $q = -1$ , and  $X > 0$  for  $q = 1$ .

Since  $q \in (-1, 1)$ , it is natural to put  $q = \cos \theta$ ,  $\theta \in (0, \pi)$ , and the metric (39) becomes

$$ds^2 = p^2(-\sin^2 \theta dt^2 + d\theta^2) + dy^2 + dp^2. \tag{43}$$

Interestingly, this form of the metric may be obtained directly from the Cartesian form of Minkowski space (40) by first applying a Rindler boost

$$\left. \begin{aligned} T &= \tilde{z} \sinh t, \\ Z &= \tilde{z} \cosh t, \end{aligned} \right\} \Rightarrow \left\{ \begin{aligned} \tanh t &= \frac{T}{Z}, \\ \tilde{z} &= \sqrt{Z^2 - T^2}, \end{aligned} \right. \tag{44}$$

in the  $Z$ -direction, thus giving the metric

$$ds^2 = -\tilde{z}^2 dt^2 + dX^2 + dY^2 + d\tilde{z}^2. \tag{45}$$

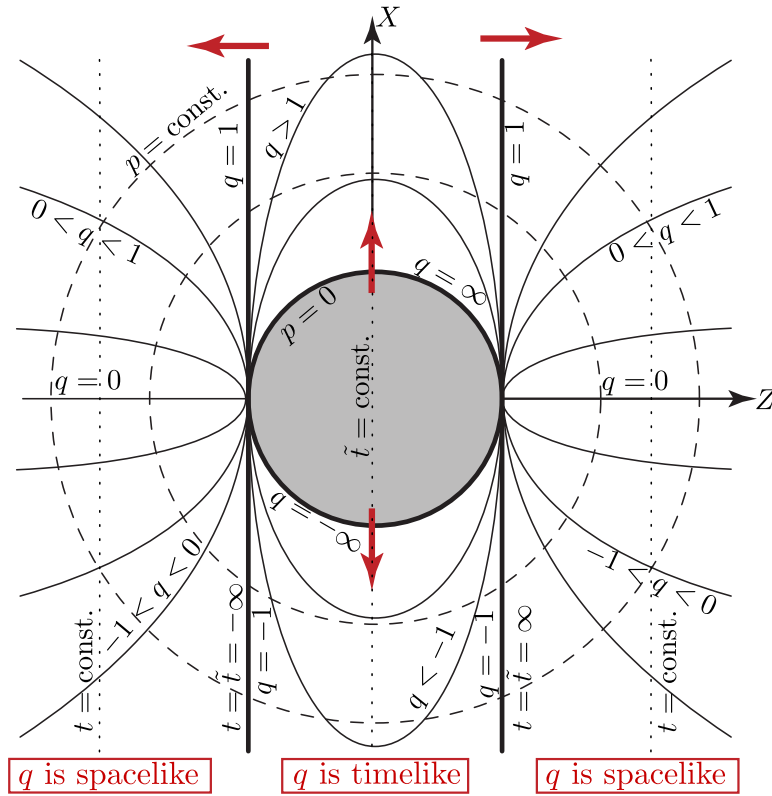

**Figure 3.** A section of the space-time (39) and (47) on which  $T$  is constant (and  $Y$  is arbitrary). For the Plebański–Demiański parameterisation of Minkowski space in which  $\epsilon_0 = +1$ , the surfaces on which  $p$  is a constant are again rotational hyperboloids (dashed concentric circles in this section) around the expanding/contracting cylinder  $p = 0, q = \pm\infty$ , see figure 2. Lines on which  $q$  is constant are illustrated for the complete range of  $q$  as hyperbolae ( $|q| < 1$ ) and ellipses ( $|q| > 1$ ). As  $T$  increases, the null planes  $q = \pm 1$  (representing Killing horizons where the norm of the vector field  $\partial_t$  vanishes) move apart, and the cylinder (whose interior is shaded) on which  $p = 0, q = \pm\infty$  simultaneously contracts/expands, at the speed of light.

By the introduction of standard polar coordinates in the  $X, \bar{z}$ -plane, namely

$$\left. \begin{aligned} X &= p \cos \theta, \\ \bar{z} &= p \sin \theta, \end{aligned} \right\} \Rightarrow \left\{ \begin{aligned} p &= \sqrt{X^2 + \bar{z}^2}, \\ \tan \theta &= \frac{\bar{z}}{X}, \end{aligned} \right. \quad (46)$$

and the relabelling  $Y = y$ , we obtain the metric (43).

- When  $|q| > 1$ ,  $q$  is a timelike coordinate while  $t$  is spacelike. In this time-dependent region, the metric (39) in the equivalent form

$$ds^2 = -\frac{p^2}{q^2 - 1} dq^2 + p^2(q^2 - 1) dt^2 + dy^2 + dp^2, \quad (47)$$

can be derived from the standard coordinates (40) of Minkowski space using the transformation

$$\left. \begin{aligned} T &= \pm p \sqrt{q^2 - 1} \cosh t, \\ X &= p q, \\ Y &= y, \\ Z &= \pm p \sqrt{q^2 - 1} \sinh t, \end{aligned} \right\} \Rightarrow \left\{ \begin{aligned} p &= \sqrt{X^2 + Z^2 - T^2}, \\ q &= \frac{X}{\sqrt{X^2 + Z^2 - T^2}}, \\ \tanh t &= \frac{Z}{T}, \\ y &= Y. \end{aligned} \right. \quad (48)$$

This is very similar to (41), just interchanging  $T$  and  $Z$  in the relation for  $t$  but, here,  $q$  is timelike. The coordinate singularity at  $p = 0$  with any finite  $q$  again corresponds to the  $Y$ -axis (that is  $T = 0$ ,  $X = 0 = Z$ ,  $Y$  arbitrary), while  $p = 0$ ,  $q = \pm\infty$  is a cylindrical surface  $X^2 + Z^2 = T^2$ , any  $Y$ , which contracts/expands at the speed of light. The metric (47) for  $q \in (1, \infty)$ , however, only covers the region of Minkowski space for which  $X > 0$  between this cylinder and the horizon represented by the pair of null hyperplanes on which  $T = \pm Z$  and  $q = 1$ . The equivalent region with  $X < 0$  is covered by the same metric (47) with  $q \in (-\infty, -1)$ . The limits where  $q = \pm 1$  are horizons.

The manifold represented by the metric (39) with the full range  $q \in (-\infty, \infty)$  thus covers the *complete* region *outside* the expanding/contracting cylinder  $X^2 + Z^2 = T^2$ , with  $Y$  arbitrary. The regions inside the cylinder are excluded. The character of such Plebański–Demiański coordinates of Minkowski space is illustrated in figures 2 and 3.

The surfaces  $p = \text{const.} \neq 0$  and  $q = \text{const.}$  are again determined by (42). On any constant  $T$  the lines  $p = \text{const.}$  are concentric circles  $X^2 + Z^2 = T^2 + p^2$  while the lines  $q = \text{const.}$  are hyperbolae for  $|q| < 1$  and ellipses for  $|q| > 1$  (in the limiting cases  $q = 0$  and  $|q| = 1$  these degenerate to straight lines  $X = 0$  and  $Z = \pm T$ , respectively). In particular, at  $T = 0$  all the curves  $q = \text{const.}$  are straight radial lines through the origin  $X = 0 = Z$ .

Notice finally that it is possible to get the flat metric (47) for  $q^2 > 1$  by first obtaining the time-dependent Kasner version of Minkowski space from the Cartesian form (40) using

$$\left. \begin{aligned} T &= \tilde{t} \cosh z, \\ Z &= \tilde{t} \sinh z, \end{aligned} \right\} \Rightarrow \left\{ \begin{aligned} \tilde{t} &= \sqrt{T^2 - Z^2}, \\ \tanh z &= \frac{Z}{T}, \end{aligned} \right. \quad (49)$$

thus giving

$$ds^2 = -d\tilde{t}^2 + dX^2 + dY^2 + \tilde{t}^2 dz^2. \quad (50)$$

We can then apply to this a Rindler boost in the  $X$ -direction, namely

$$\left. \begin{aligned} \tilde{t} &= \pm p \sinh \tau, \\ X &= \pm p \cosh \tau, \\ Y &= y, \end{aligned} \right\} \Rightarrow \left\{ \begin{aligned} p &= \sqrt{X^2 - \tilde{t}^2}, \\ \tanh \tau &= \frac{\tilde{t}}{X}, \\ y &= Y. \end{aligned} \right. \quad (51)$$

With this, the metric becomes

$$ds^2 = p^2(-d\tau^2 + \sinh^2 \tau dz^2) + dy^2 + dp^2, \quad (52)$$

which is exactly the metric (47) with  $q = \cosh \tau$  and  $t = z$ .

**5.1.2. The case  $\epsilon_0 = 0$ .** In this case, the Plebański–Demiański form of the flat metric (38) is

$$ds^2 = -\frac{p^2}{q^2} dq^2 + p^2 q^2 dt^2 + dy^2 + dp^2. \quad (53)$$

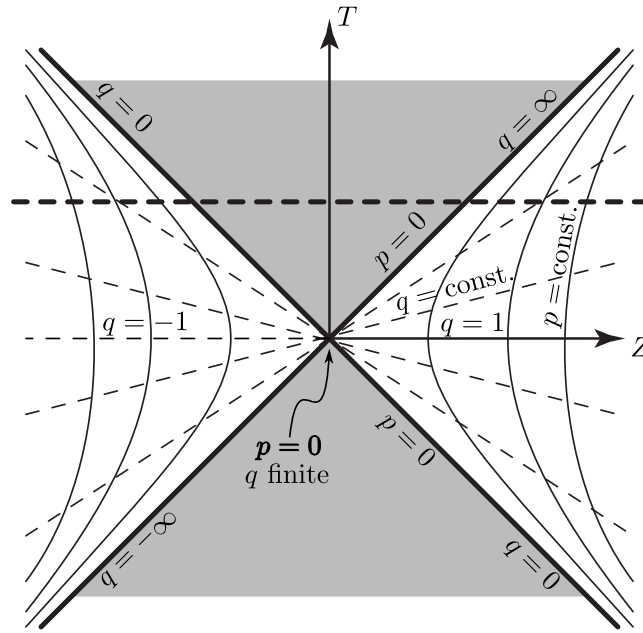

**Figure 4.** A section  $X = 0$  (corresponding to  $t = 0$ ) of the background Minkowski space for the Plebański–Demiański parameterisation with  $\epsilon_0 = 0$ . The surfaces on which  $p > 0$  is a constant are rotational hyperboloids  $-T^2 + X^2 + Z^2 = p^2$  around the expanding/contracting cylinder  $X^2 + Z^2 = T^2$ , arbitrary  $Y = y$ , on which  $p = 0$ ,  $q = \pm\infty$ . The surfaces on which  $q$  is constant are planes through the spacelike line on which  $T = 0 = Z$ , with  $X, Y$  arbitrary. The horizontal heavy dashed line indicates the section  $T = \text{const.}$  through the space-time that is illustrated in figure 5. The shaded regions are not covered by the Plebański–Demiański coordinates.

It can be derived from the standard form (40) of Minkowski space via the transformation

$$\left. \begin{aligned} T + Z &= pq, \\ T - Z &= \frac{p}{q}(q^2 t^2 - 1), \\ X &= pqt, \\ Y &= y, \end{aligned} \right\} \Rightarrow \begin{cases} p = \sqrt{X^2 + Z^2 - T^2}, \\ q = \frac{T + Z}{\sqrt{X^2 + Z^2 - T^2}}, \\ t = \frac{X}{T + Z}, \\ y = Y, \end{cases} \quad (54)$$

where  $q, t, y \in (-\infty, \infty)$  and  $p \in [0, \infty)$ . The coordinate singularity  $p = 0$  (with finite  $q, t$ ) again corresponds to  $T = 0$ ,  $X = 0 = Z$ ,  $Y$  arbitrary. The surfaces  $p = \text{const.} > 0$  are again given by (42), i.e. they are rotational hyperboloids  $X^2 + Z^2 = T^2 + p^2$  outside the contracting/expanding cylinder  $X^2 + Z^2 = T^2$  (corresponding to the singularity  $p = 0$  with  $q = \pm\infty$ ), as shown in figure 4. For  $X = 0$  this cylinder reduces to  $T = \pm Z$  which coincides with the Killing horizon discussed in the case  $\epsilon_0 = +1$ .

However, the surfaces  $q = \text{const.}$  and  $t = \text{const.}$  are now different, namely

$$X^2 + \frac{q^2 - 1}{q^2} \left( Z - \frac{1}{q^2 - 1} T \right)^2 = \frac{q^2}{q^2 - 1} T^2, \quad \text{and} \quad X = t(T + Z). \quad (55)$$

On the section  $X = 0$  this reduces to straight lines  $T = \frac{q^2 - 1}{q^2 + 1} Z$ ,  $T = -Z$ , with  $t = 0$ .

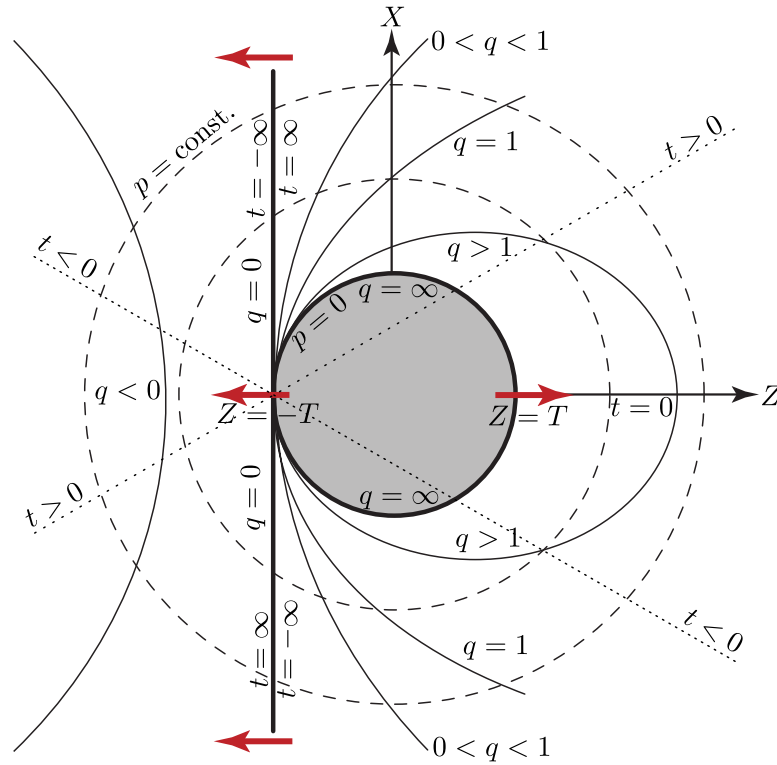

**Figure 5.** A section of the space-time on which  $T > 0$  is constant (and  $Y$  is arbitrary). For the Plebański–Demiański parameterisation of Minkowski space in which  $\epsilon_0 = 0$ , the surfaces on which  $p$  is a constant are again rotational hyperboloids (dashed concentric circles in this section) around the expanding/contracting cylinder  $p = 0$ . Lines on which  $q$  is constant are illustrated for the complete range:  $q = \infty$  is a circle which coincides with the coordinate singularity  $p = 0$ , lines  $q > 1$  are ellipses,  $q = 1$  is a parabola, and  $|q| < 1$  are hyperbolae. The coordinate singularity at  $q = 0$  corresponds to the Killing horizon where the norm of  $\partial_t$  vanishes. As  $T$  increases, the line  $q = 0$  moves to the left and the null cylinder  $p = 0$  expands at the speed of light (see the red arrows). All the coordinate lines  $q = \text{const.} \geq 0$  intersect in a singular point  $Z = -T$ , which is a degenerate point on this expanding cylinder (a null line  $X = 0, Z = -T, Y$  arbitrary).

On a section on which  $T$  is any constant, all the curves  $q = \text{const.}$  are *conic sections*. In particular,  $q = \infty$  corresponds to the circle  $X^2 + Z^2 = T^2$  (which is the singularity  $p = 0, q = \infty$ ). For  $q > 1$  the curves are ellipses with the semi-major axis  $\frac{q^2}{q^2-1} T$  oriented along  $Z$ . The curve  $q = 1$  degenerates to a parabola  $Z = \frac{1}{2T} X^2 - T$ , and for  $|q| < 1$  these coordinate lines are hyperbolae. The line  $q = 0$  is a straight line  $Z = -T$  with  $X$  arbitrary. This is illustrated in figure 5. Moreover, *all these curves for  $q \geq 0$  intersect at the singular point  $Z = -T < 0, X = 0$* . Notice also that  $q > 0 \Leftrightarrow Z > -T$  whereas  $q < 0 \Leftrightarrow Z < -T$ . In the special case  $T = 0$  the coordinate lines  $q = \text{const.}$  are radial straight lines  $X \propto Z$ . For any fixed  $T$ , the coordinate lines  $t = \text{const.}$  are just *straight lines  $X = tZ + tT$*  which all intersect  $X = 0$  at the singular point  $Z = -T$ .

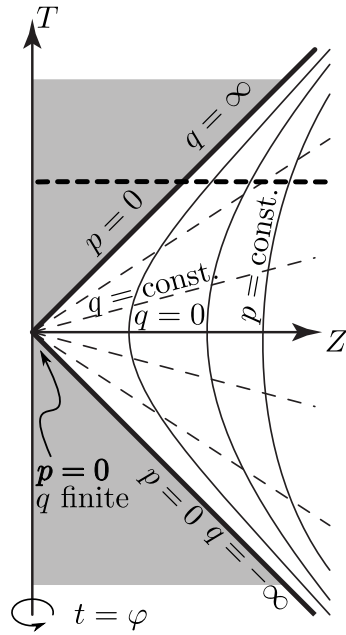

**Figure 6.** A section of the background flat space with  $\epsilon_0 = -1$  on which  $X = 0$  (and  $Y = y$  is any constant), corresponding to  $t = 0$ . The surfaces on which  $p > 0$  is a constant are rotational hyperboloids  $-T^2 + X^2 + Z^2 = p^2$  around the expanding/contracting cylinder  $X^2 + Z^2 = T^2$ ,  $Y$  arbitrary, on which  $p = 0$ ,  $q = \pm\infty$ . The surfaces on which  $q$  is constant are cones with vertices on the spacelike plane  $X, Y$  arbitrary and  $T = 0 = Z$ . The shaded regions are not covered. A typical horizontal section  $T = \text{const.}$  through the space-time is illustrated in figure 7.

Finally, notice that the flat Plebański–Demiański-type metric (53) can be rewritten as

$$ds^2 = p^2(-d\tau^2 + e^{2\tau} dt^2) + dy^2 + dp^2, \tag{56}$$

by introducing  $\tau = \log |q|$ . Clearly,  $p = 0$  is just the  $y$ -axis.

5.1.3. *The case  $\epsilon_0 = -1$*  In this case, the Plebański–Demiański form of the metric (38) is

$$ds^2 = -\frac{p^2}{1+q^2} dq^2 + p^2(1+q^2) dt^2 + dy^2 + dp^2, \tag{57}$$

in which  $q$  is a *timelike* coordinate. This metric can be derived from the standard Cartesian coordinates of Minkowski space using the transformation (with the Jacobian  $|J| = p^2$ )

$$\left. \begin{aligned} T &= pq, \\ X &= p\sqrt{1+q^2}\sin t, \\ Y &= y, \\ Z &= p\sqrt{1+q^2}\cos t, \end{aligned} \right\} \Rightarrow \left\{ \begin{aligned} p &= \sqrt{X^2 + Z^2 - T^2}, \\ q &= \frac{T}{\sqrt{X^2 + Z^2 - T^2}}, \\ \tan t &= \frac{X}{Z}, \\ y &= Y, \end{aligned} \right. \tag{58}$$



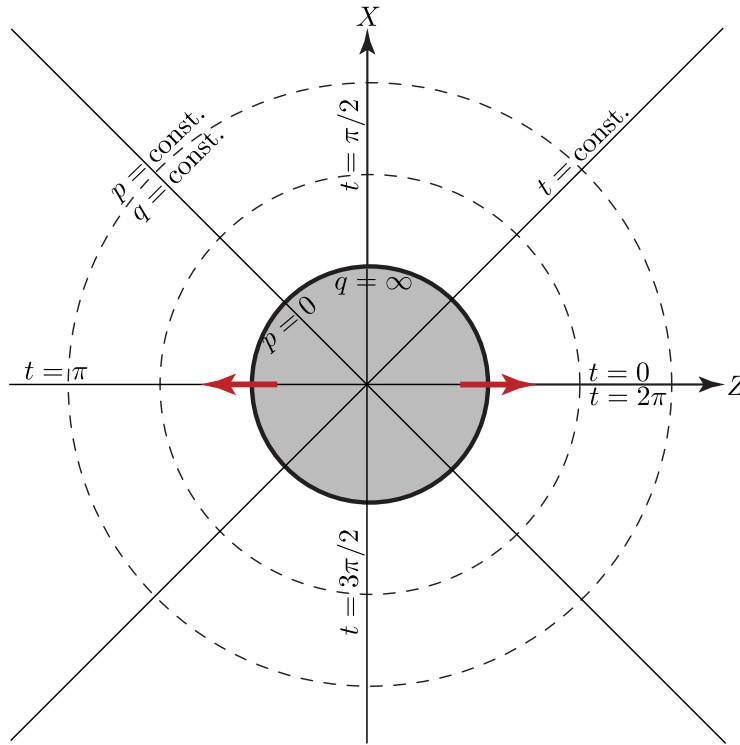

**Figure 7.** A section  $T = \text{const.}$  through the flat space-time with  $\epsilon_0 = -1$  ( $Y = y$  is constant). Both the lines  $p = \text{const.}$  and  $q = \text{const.}$  are circles, while  $t = \text{const.}$  are radial straight lines. In this parameterization (57) there is no Killing horizon associated with  $\partial_t \equiv \partial_\varphi$ .

where  $q, y \in (-\infty, \infty)$  and  $p \in [0, \infty)$ . It can again be seen that the coordinate singularity at  $p = 0$  corresponds to  $T = 0$ ,  $X = 0 = Z$ , with  $Y$  arbitrary. The surfaces  $p = \text{const.} > 0$  are rotational hyperboloids (42) outside the cylinder  $X^2 + Z^2 = T^2$  which expands or contracts at the speed of light (corresponding to the singularity  $p = 0$  with  $q = \infty$  or  $q = -\infty$ , respectively). The above metric only represents the region that is exterior to this hypersurface.

It is also now clear from (58) that the spatial coordinate  $t$  may be taken to be *periodic* with  $t \in [0, 2\pi)$  and  $t = 2\pi$  identified with  $t = 0$ . And, with this angular coordinate  $t$ , the complete exterior is covered. This is illustrated in figures 6 and 7.

It is thus appropriate to relabel  $t \equiv \varphi$  and to put  $q = \sinh \tau$ , so that the metric (57) takes the form

$$ds^2 = p^2(-d\tau^2 + \cosh^2 \tau d\varphi^2) + dy^2 + dp^2. \quad (59)$$

Interestingly, this form of the metric may be obtained from the Cartesian form of Minkowski space by first introducing polar coordinates in the  $X$ - $Z$  plane as

$$\left. \begin{aligned} X &= \rho \sin \varphi, \\ Z &= \rho \cos \varphi, \end{aligned} \right\} \Rightarrow \left\{ \begin{aligned} \rho &= \sqrt{X^2 + Z^2}, \\ \tan \varphi &= \frac{X}{Z}, \end{aligned} \right. \quad (60)$$

thus giving the cylindrical metric

$$ds^2 = -dT^2 + d\rho^2 + dY^2 + \rho^2 d\varphi^2, \quad (61)$$

and then applying a Rindler boost in the  $\rho$ -direction, namely

$$\left. \begin{aligned} p &= \sqrt{\rho^2 - T^2}, \\ \tanh \tau &= \frac{T}{\rho}, \end{aligned} \right\} \Rightarrow \begin{cases} T = p \sinh \tau, \\ \rho = p \cosh \tau, \end{cases} \quad (62)$$

with  $Y = y$ . The metric (59) may thus be understood as specific accelerating coordinates.

Of course, direct transformations between the metric forms (39), (53) and (57) can be easily obtained by comparing the relations (41), (48), (54) and (58).

## 6. The (anti-)de Sitter background: $\Lambda \neq 0$ ( $n, \gamma, \mathbf{e}, \mathbf{g} = \mathbf{0}$ )

Consider now the above family of Plebański–Demiański solutions in the *conformally flat subcase* in which  $\gamma, n, e, g$  are all set to zero but  $\Lambda \neq 0$ , see (24). The metric (22), (23) then reads

$$ds^2 = p^2 \left( -Q dt^2 + \frac{1}{Q} dq^2 \right) + P dy^2 + \frac{1}{p} dp^2, \quad (63)$$

where  $Q$  and  $P \equiv \mathcal{P}/p^2$  are

$$Q(q) = \epsilon_0 - \epsilon_2 q^2, \quad P(p) = \epsilon_2 - \frac{1}{3} \Lambda p^2. \quad (64)$$

This is an *unusual family of metrics of the maximally symmetric de Sitter and anti-de Sitter space-times*. The (anti-)de Sitter manifold can be visualized, see e.g. [3], as the hyperboloid

$$-Z_0^2 + Z_1^2 + Z_2^2 + Z_3^2 + \epsilon Z_4^2 = \epsilon a^2, \quad \text{where } a = \sqrt{3/|\Lambda|}, \quad \epsilon = \text{sign } \Lambda, \quad (65)$$

embedded in a flat five-dimensional Minkowski space

$$ds^2 = -dZ_0^2 + dZ_1^2 + dZ_2^2 + dZ_3^2 + \epsilon dZ_4^2. \quad (66)$$

The coordinates of (63) are adapted to a specific  $2 + 2$  foliations of this manifold, and the geometry of such parametrizations is a *warped product* of two  $2$ -spaces of constant curvature, namely  $dS_2, M_2, AdS_2$  (according to the sign of  $\epsilon_2$ ) spanned by  $t, q$ , and  $S^2, E^2, H^2$  (according to sign of  $\Lambda$ ) spanned by  $y, p$ . The warp factor is  $p^2$ .

In our recent work [11] we have thoroughly studied and visualized this new family of diagonal static metrics for all possible choices of  $\epsilon_0, \epsilon_2$  and for any  $\Lambda \neq 0$ . In fact there are 3 allowed distinct subcases for  $\Lambda > 0$  and 8 subcases for  $\Lambda < 0$ , summarized in table 1. It is not necessary to repeat all the specific metric forms, transformations, figures and other details presented in [11]. In this section we will only mention the most interesting subcases of such Plebański–Demiański representation of (anti-)de Sitter spaces.

### 6.1. The de Sitter space in Plebański–Demiański coordinates

**6.1.1.  $\Lambda > 0, \epsilon_2 = +1, \epsilon_0 = -1$**  This choice of  $\epsilon_2, \epsilon_0$  seems to be the most natural one for the case  $\Lambda > 0$ . The corresponding coordinates, with  $y \equiv a\phi$ , cover the (part of) de Sitter hyperboloid (65) as

**Table 1.** Summary of all admitted subcases given by different values of the discrete parameters  $\epsilon_2, \epsilon_0$ , for  $\Lambda > 0$  (upper part) and  $\Lambda < 0$  (lower part).

$\Lambda$	$\epsilon_2$	$\epsilon_0$	$P$	Range of $p$	$Q$	Range of $q$
$>0$	+1	+1	$1 - p^2/a^2$	$(-a, a)$	$1 - q^2$	$\mathbb{R} \setminus \{\pm 1\}$
$>0$	+1	0	$1 - p^2/a^2$	$[0, a)$	$-q^2$	$\mathbb{R} \setminus \{0\}$
$>0$	+1	-1	$1 - p^2/a^2$	$[0, a)$	$-1 - q^2$	$\mathbb{R}$
$<0$	+1	+1	$1 + p^2/a^2$	$\mathbb{R}$	$1 - q^2$	$\mathbb{R} \setminus \{\pm 1\}$
$<0$	+1	0	$1 + p^2/a^2$	$[0, \infty)$	$-q^2$	$\mathbb{R} \setminus \{0\}$
$<0$	+1	-1	$1 + p^2/a^2$	$[0, \infty)$	$-1 - q^2$	$\mathbb{R}$
$<0$	0	+1	$p^2/a^2$	$\mathbb{R}$	1	$\mathbb{R}$
$<0$	0	-1	$p^2/a^2$	$\mathbb{R}$	-1	$\mathbb{R}$
$<0$	-1	+1	$-1 + p^2/a^2$	$[a, \infty)$	$1 + q^2$	$\mathbb{R}$
$<0$	-1	0	$-1 + p^2/a^2$	$[a, \infty)$	$q^2$	$\mathbb{R} \setminus \{0\}$
$<0$	-1	-1	$-1 + p^2/a^2$	$\mathbb{R} \setminus (-a, a)$	$-1 + q^2$	$\mathbb{R} \setminus \{\pm 1\}$

$$\left. \begin{aligned} Z_0 &= pq, \\ Z_1 &= p\sqrt{1+q^2}\cos t, \\ Z_2 &= p\sqrt{1+q^2}\sin t, \\ Z_3 &= \sqrt{a^2-p^2}\cos\phi, \\ Z_4 &= \sqrt{a^2-p^2}\sin\phi, \end{aligned} \right\} \Rightarrow \left\{ \begin{aligned} p &= \sqrt{Z_1^2 + Z_2^2 - Z_0^2}, \\ q &= \frac{Z_0}{\sqrt{Z_1^2 + Z_2^2 - Z_0^2}}, \\ \tan t &= \frac{Z_2}{Z_1}, \\ \tan\phi &= \frac{Z_4}{Z_3}. \end{aligned} \right. \quad (67)$$

Such a parametrization is visualized in figure 8 as two sections of the de Sitter hyperboloid. The coordinate singularity  $p = 0$  clearly corresponds to  $Z_0 = Z_1 = Z_2 = 0$ ,  $Z_3 = a \cos \phi$ ,  $Z_4 = a \sin \phi$ . It is convenient to put  $q = \sinh \tau$  and  $t = \varphi$ . The metric (63), (64) thus takes the form

$$ds^2 = p^2(-d\tau^2 + \cosh^2 \tau d\varphi^2) + (a^2 - p^2) d\phi^2 + \frac{a^2 dp^2}{a^2 - p^2}. \quad (68)$$

The range of  $p$  is finite, namely  $p \in [0, \sqrt{3/\Lambda})$ , to maintain the correct signature  $(-+++)$ , while  $\tau \in \mathbb{R}$  and  $\varphi, \phi \in [0, 2\pi)$ . For  $\Lambda \rightarrow 0$ , this de Sitter metric reduces to the line element (59) of flat space.

## 6.2. The anti-de Sitter space in Plebański–Demiański coordinates

6.2.1.  $\Lambda < 0, \epsilon_2 = 0, \epsilon_0 = +1$  In this case (63) simplifies considerably to

$$ds^2 = p^2(-dt^2 + dq^2) + \frac{p^2}{a^2} dy^2 + \frac{a^2}{p^2} dp^2, \quad (69)$$

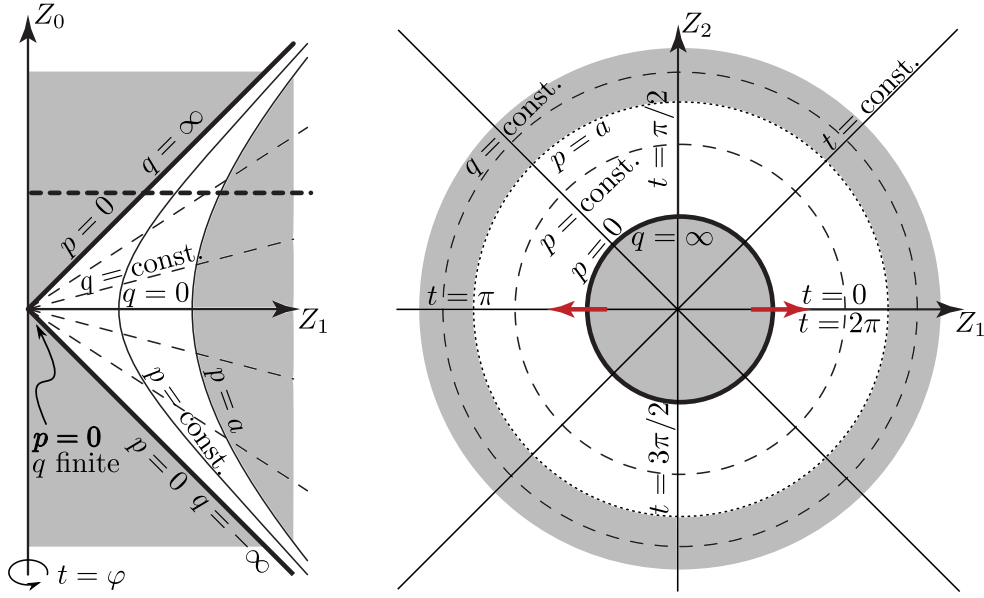

**Figure 8.** Sections  $Z_1$ - $Z_0$  (left) and  $Z_1$ - $Z_2$  (right) of the background de Sitter space, represented as the hyperboloid (65) in 5-dimensional flat space, with Plebański–Demiański coordinates (63), (64) given by  $\epsilon_2 = 1$ ,  $\epsilon_0 = -1$ . The shaded regions are not covered by these coordinates. Notice a close similarity with the  $\epsilon_2 = 1$ ,  $\epsilon_0 = -1$  coordinates of flat Minkowski space visualized in figures 6 and 7.

where  $a = \sqrt{3/|\Lambda|}$ . With a simple transformation

$$p = \frac{a^2}{x}, \quad t = \frac{\eta}{a}, \quad q = \frac{z}{a}, \quad (70)$$

$\eta, x, y, z \in \mathbb{R}$  ( $x \neq 0$ ), we obtain the metric

$$ds^2 = \frac{a^2}{x^2} (-d\eta^2 + dx^2 + dy^2 + dz^2). \quad (71)$$

This is exactly the *conformally flat Poincaré form of anti-de Sitter space-time*, see e.g. metric (5.14) in [3]. These well-known coordinates have been thoroughly described and employed in literature (for example in the works on AdS/CFT correspondence). The corresponding explicit parametrization of the anti-de Sitter hyperboloid (65) by (69) is

$$\left. \begin{aligned} Z_0 &= \frac{p}{2} \left( 1 + \frac{s}{a^2} \right), \\ Z_1 &= \frac{p}{2} \left( 1 - \frac{s}{a^2} \right), \\ Z_2 &= pq, \\ Z_3 &= py/a, \\ Z_4 &= pt, \end{aligned} \right\} \Rightarrow \left\{ \begin{aligned} p &= Z_0 + Z_1, \\ q &= \frac{Z_2}{Z_0 + Z_1}, \\ t &= \frac{Z_4}{Z_0 + Z_1}, \\ y &= \frac{aZ_3}{Z_0 + Z_1}, \end{aligned} \right. \quad (72)$$

where  $s/a^2 = -t^2 + q^2 + y^2/a^2 + a^2/p^2$ . The corresponding sections through the anti-de Sitter hyperboloids are shown in figure 9.

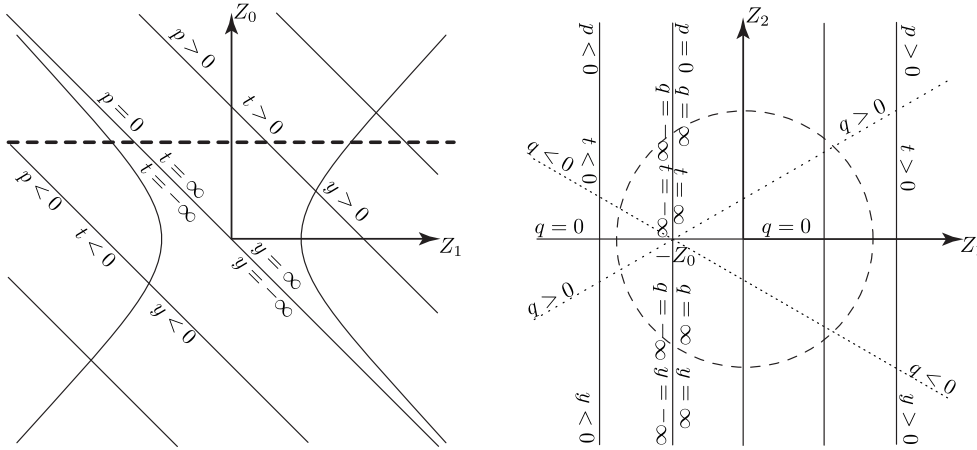

**Figure 9.** Sections  $Z_1$ - $Z_0$  (left) and  $Z_1$ - $Z_2$  (right) with  $Z_3, Z_4 = \text{const.} > 0$  of the background anti-de Sitter space, represented as the hyperboloid (65) in 5-dimensional flat space, with Plebański–Demiański coordinates (69) given by  $\epsilon_2 = 0, \epsilon_0 = +1$ .

6.2.2.  $\Lambda < 0, \epsilon_2 = +1, \epsilon_0 = +1$  This choice of parameters gives the anti-de Sitter space in the Plebański–Demiański form

$$ds^2 = -p^2(1 - q^2) dt^2 + \frac{p^2}{1 - q^2} dq^2 + (a^2 + p^2) \frac{dy^2}{a^2} + \frac{a^2 dp^2}{a^2 + p^2}, \quad (73)$$

where  $p, t, y \in \mathbb{R}, q \in \mathbb{R} \setminus \{\pm 1\}$ . This is a generalization of the flat metric (39) to  $\Lambda < 0$ . The separate subcases  $|q| < 1$  and  $|q| > 1$  are:

- For  $|q| < 1$ , the coordinates of (73) parametrize the anti-de Sitter hyperboloid (65) as

$$\left. \begin{aligned} Z_0 &= p \sqrt{1 - q^2} \sinh t, \\ Z_1 &= p \sqrt{1 - q^2} \cosh t, \\ Z_2 &= |p| q, \\ Z_3 &= \pm \sqrt{a^2 + p^2} \sinh \frac{y}{a}, \\ Z_4 &= \pm \sqrt{a^2 + p^2} \cosh \frac{y}{a}, \end{aligned} \right\} \Rightarrow \begin{cases} \tanh t = \frac{Z_0}{Z_1}, \\ \tanh \frac{y}{a} = \frac{Z_3}{Z_4}, \\ p = \text{sign}(Z_1) \sqrt{Z_1^2 + Z_2^2 - Z_0^2}, \\ q = \frac{Z_2}{\sqrt{Z_1^2 + Z_2^2 - Z_0^2}}. \end{cases} \quad (74)$$

This parametrization gives two maps covering the anti-de Sitter manifold, namely the coordinate map  $Z_4 \geq a$  for the ‘+’ sign, and  $Z_4 \leq a$  for the ‘-’ sign (and two maps  $p > 0$  and  $p < 0$ ). Moreover,  $q > 0$  corresponds to  $Z_2 > 0$ , while  $q < 0$  corresponds to  $Z_2 < 0$ .

- For  $|q| > 1$ , the parametrization is the same as (74), except that now

$$\left. \begin{aligned} Z_0 &= p \sqrt{q^2 - 1} \cosh t, \\ Z_1 &= p \sqrt{q^2 - 1} \sinh t, \end{aligned} \right\} \Rightarrow \begin{cases} \tanh t = \frac{Z_1}{Z_0}, \\ p = \text{sign}(Z_0) \sqrt{Z_1^2 + Z_2^2 - Z_0^2}. \end{cases} \quad (75)$$

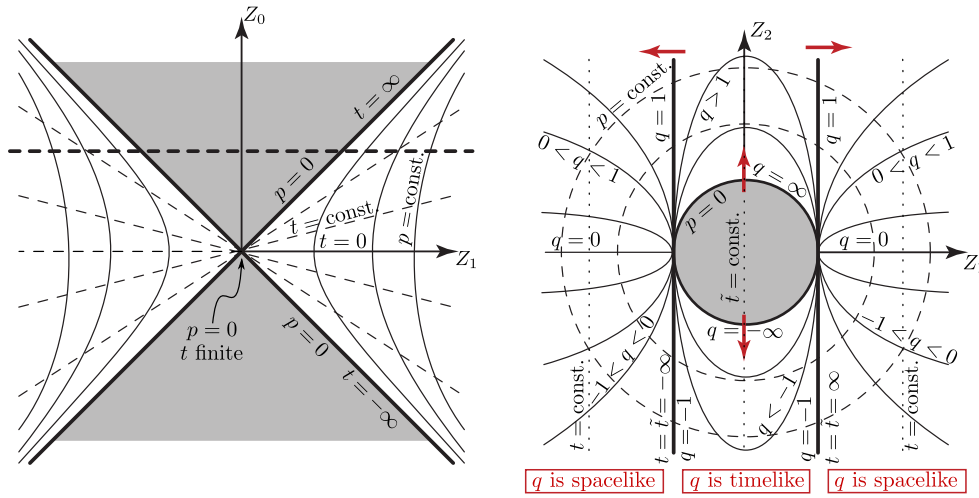

**Figure 10.** Sections  $Z_1$ - $Z_0$  (left) and  $Z_1$ - $Z_2$  for  $Z_0 = \text{const.} > 0$  (right) of the background anti-de Sitter space, represented as the hyperboloid (65) in 5-dimensional flat space, with Plebański–Demiański coordinates (73) given by  $\epsilon_2 = +1$ ,  $\epsilon_0 = +1$ . The shaded regions are not covered. It resembles the corresponding case of flat Minkowski space visualized in figures 2 and 3.

In both cases, it can be immediately observed that the coordinate singularity  $p = 0$  (with finite values of the coordinates  $t, q$ ) is located at  $Z_0 = Z_1 = Z_2 = 0$  with  $Z_3 = \pm a \sinh(y/a)$ ,  $Z_4 = \pm a \cosh(y/a)$ . This is a *main hyperbolic line on the hyperboloid* (65) representing the anti-de Sitter universe.

Sections  $Z_1$ - $Z_0$  and  $Z_1$ - $Z_2$  through the anti-de Sitter space-time are illustrated in figure 10.

6.2.3.  $\Lambda < 0$ ,  $\epsilon_2 = -1$ ,  $\epsilon_0 = 1$ . Relabeling  $y = a\phi$ , the metric (63), (64) reads

$$ds^2 = -p^2(1 + q^2) dt^2 + \frac{p^2}{1 + q^2} dq^2 + (p^2 - a^2) d\phi^2 + \frac{a^2 dp^2}{p^2 - a^2}, \quad (76)$$

where  $p \in [a, \infty)$ ,  $q \in \mathbb{R}$ ,  $t, \phi \in [0, 2\pi)$ , with  $p = a$  representing the axis of symmetry.

This arises as the parametrization

$$\left. \begin{aligned} Z_0 &= p \sqrt{1 + q^2} \cos t, \\ Z_1 &= p q, \\ Z_2 &= \sqrt{p^2 - a^2} \cos \phi, \\ Z_3 &= \sqrt{p^2 - a^2} \sin \phi, \\ Z_4 &= p \sqrt{1 + q^2} \sin t, \end{aligned} \right\} \Leftrightarrow \left\{ \begin{aligned} \tan t &= \frac{Z_4}{Z_0}, \\ \tan \phi &= \frac{Z_3}{Z_2}, \\ p &= \sqrt{Z_0^2 - Z_1^2 + Z_4^2}, \\ q &= \frac{Z_1}{\sqrt{Z_0^2 - Z_1^2 + Z_4^2}}, \end{aligned} \right. \quad (77)$$

of the anti-de Sitter hyperboloid (65). Recall that  $Z_0$  and  $Z_4$  are two temporal coordinates expressed here by the most natural single temporal coordinate  $t \in [0, 2\pi)$ . The covering space is obtained by allowing  $t \in \mathbb{R}$  in (76).

Interestingly, after the formal relabeling  $Z_0 \leftrightarrow Z_1$  and  $Z_2 \rightarrow Z_3 \rightarrow Z_4 \rightarrow Z_2$  we obtain basically the same expressions as (67) for the de Sitter subcase  $\Lambda > 0$ ,  $\epsilon_2 = 1$ ,  $\epsilon_0 = -1$ . Therefore, the sections through the anti-de Sitter hyperboloid closely resemble those shown in figure 8,

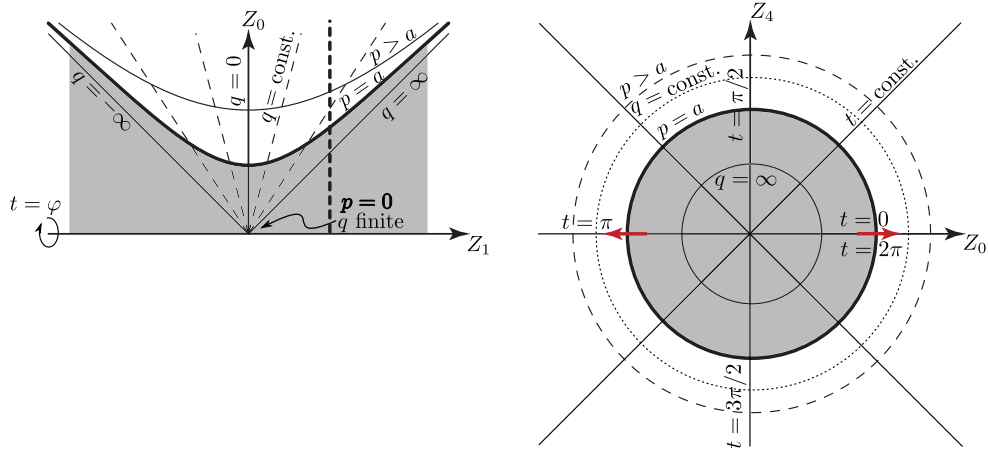

**Figure 11.** Sections  $Z_1$ - $Z_0$  (left) and  $Z_0$ - $Z_4$  for  $Z_1 = \text{const.} > 0$  (right) of the anti-de Sitter space (65) with Plebański–Demiański coordinates (76) given by  $\epsilon_2 = -1$ ,  $\epsilon_0 = 1$ . It resembles the corresponding case of the de Sitter space visualized in figure 8.

after the relabeling of the axes  $Z_a$  and reconsidering different ranges of the coordinates. In particular, in figure 11 we plot the sections  $Z_4 = 0$  and  $Z_1 = \text{const.} > 0$ , respectively. It can be seen from (77) that these coordinates cover the whole anti-de Sitter universe.

More information about the global character of these coordinates, other cases given by different choices of the parameters  $\epsilon_2$ ,  $\epsilon_0$ , their mutual relations and properties can be found in our previous paper [11].

### 7. The $B$ -metrics: $n \neq 0$ ( $\gamma, \mathbf{e}, \mathbf{g}, \Lambda = 0$ )

To elucidate the meaning of the physical parameter  $n$ , we first consider the case when  $\gamma = 0 = \Lambda$  and  $e = 0 = g$ . Such vacuum solutions are known as the  $B$ -metrics, following the classification of Ehlers and Kundt [12].

The subcases of such  $B$ -metrics are then distinguished by two discrete parameters  $\epsilon_2$  and  $\epsilon_0$ , with possible values  $+1, 0, -1$ . The corresponding metric (22), (23) is

$$ds^2 = -p^2(\epsilon_0 - \epsilon_2 q^2) dt^2 + \frac{p^2}{\epsilon_0 - \epsilon_2 q^2} dq^2 + \left(\epsilon_2 + \frac{2n}{p}\right) dy^2 + \left(\epsilon_2 + \frac{2n}{p}\right)^{-1} dp^2. \quad (78)$$

When  $n$  is set to zero, this metric immediately reduces to background (37). The space-times (78) admit four Killing vectors.

In all the subcases, the only non-zero Weyl NP scalar (24) is given by

$$\Psi_2 = \frac{n}{p^3}, \quad (79)$$

where the two (double degenerate) principal null directions are

$$\mathbf{k} = -\frac{1}{\sqrt{2}p} \left( \frac{1}{\sqrt{\epsilon_0 - \epsilon_2 q^2}} \partial_t + \sqrt{\epsilon_0 - \epsilon_2 q^2} \partial_q \right),$$

$$\mathbf{l} = -\frac{1}{\sqrt{2}p} \left( \frac{1}{\sqrt{\epsilon_0 - \epsilon_2 q^2}} \partial_t - \sqrt{\epsilon_0 - \epsilon_2 q^2} \partial_q \right),$$

see (13). They span 2-dimensional spatial surfaces  $p = \text{const.}$ ,  $y = \text{const.}$  This confirms that all  $B$ -metrics are of *type D* and possess a *curvature singularity at  $p = 0$* . It is convenient to consider only solutions for which  $p$  is positive, but the parameter  $n$  may have either sign (notice that the metric only depends on their fraction  $n/p$ ).

It seems that most of the  $B$ -metrics have not yet been studied and physically interpreted, although they are a very simple family of type D space-times that have been known for a long time. Moreover, they are formally related to the well-known  $A$ -metrics by a complex coordinate transformation. If the  $y$ -coordinate is taken to have a finite range  $[0, 2\pi)$ , with  $y = 2\pi$  identified with  $y = 0$ , the static regions of these space-times can be expressed in Weyl form. In this case, the associated Newtonian potentials have been identified by Martins [13] as semi-infinite line masses. However, the physical interpretation of these space-times clearly requires further investigation. Let us present here some observations concerning the physical and geometrical properties of the class of exact space-times (78).

### 7.1. The $BI$ -metric ( $\epsilon_2 = 1$ )

This case  $\epsilon_2 = 1$  admits three subcases, namely  $\epsilon_0 = 1, 0, -1$ .

7.1.1. *The  $BI$ -metric with  $\epsilon_0 = 1$ .* For the choice  $\epsilon_0 = 1$  the line element becomes

$$ds^2 = -p^2(1 - q^2) dt^2 + \frac{p^2}{1 - q^2} dq^2 + \left(1 + \frac{2n}{p}\right) dy^2 + \left(1 + \frac{2n}{p}\right)^{-1} dp^2, \quad (80)$$

generalizing (39). If  $n > 0$  and  $p \in (0, \infty)$ , there is a *physical singularity at  $p = 0$* . Alternatively, if  $n < 0$ , this represents a *non-singular* space-time with  $p \in (2|n|, \infty)$ . Both cases are asymptotically flat as  $p \rightarrow \infty$ .

The character of the singularity at  $p = 0$  can be elucidated by considering the weak-field limit of the metric (80) as  $n \rightarrow 0$ , with positive  $n$ . In view of both explicit transformations (41) and (48) to usual Cartesian coordinates of the background Minkowski space it is clear, that the *curvature singularity at  $p = 0$  corresponds to*

$$T = 0, \quad X = 0 = Z, \quad Y = y. \quad (81)$$

It is localized *along the spatial  $Y$ -axis*, i.e. it can be interpreted as the source associated with a tachyon which moves (with infinite velocity) at  $T = 0$  along the  $Y$ -axis. The curved  $BI$ -metric (80) can thus be understood to include the *gravitational field generated by a tachyon moving instantaneously along a straight line* (the  $y$ -axis).

Following an analogy with the  $AI$ -metric, which represents the gravitational field of a static (standing) mass source, it is natural to put  $q = \cos \theta$  in (80). However, this is unnecessarily restrictive. The coordinate  $q$  may cover the complete range  $q \in (-\infty, \infty)$ . For the range  $|q| > 1$ , the space-time is time-dependent and  $q$  is a timelike coordinate. Horizons exist at  $q = \pm 1$ , between which the space-time is static. However, from an analysis of the Minkowski limit as  $n \rightarrow 0$ , performed in section 5.1, it would appear that the Killing horizons at  $q = \pm 1$  have the character of acceleration horizons in this particular coordinate representation. Moreover, this choice of  $\epsilon_0 = +1$  seems to correspond to an ‘unfortunate’ coordinate foliation with coordinate singularities at  $q = \pm 1$ .

7.1.2. *The  $BI$ -metric with  $\epsilon_0 = -1$ .* Another metric form, which covers the space-time without the coordinate singularity at  $q = \pm 1$ , occurs with the choice  $\epsilon_0 = -1$ . In this case, relabelling  $t = \varphi \in [0, 2\pi)$ , the metric is



$$ds^2 = -\frac{p^2}{1+q^2} dq^2 + p^2(1+q^2) d\varphi^2 + \left(1 + \frac{2n}{p}\right) dy^2 + \left(1 + \frac{2n}{p}\right)^{-1} dp^2, \quad (82)$$

generalizing (57). Putting  $q = \sinh \tau$ , it takes the form

$$ds^2 = p^2 \left(-d\tau^2 + \cosh^2 \tau d\varphi^2\right) + \left(1 + \frac{2n}{p}\right) dy^2 + \left(1 + \frac{2n}{p}\right)^{-1} dp^2. \quad (83)$$

This is a time-dependent, cylindrically symmetric form of the curved *BI*-metric, generalizing the flat metric (59). In fact, it is the metric (11.22) in the paper by Plebański [6]. Again, if  $n > 0$  then  $p \in (0, \infty)$ . Alternatively, if  $n < 0$ , this represents a non-singular region of space-time with  $p \in (2|n|, \infty)$ . Both cases are asymptotically flat as  $p \rightarrow \infty$ .

This form of the *BI*-metric solution was analyzed in 1974 by Gott [14] and interpreted as part of the space-time with  $n < 0$  containing a tachyonic matter source (the other part of the space-time can be extended by the *AII*-metric). Indeed, by inspecting the explicit transformation (58) to the background Cartesian coordinates we immediately obtain that the singularity at  $p = 0$  in the weak-field limit  $n \rightarrow 0$  is again located at (81), i.e. along the spatial *Y*-axis. This confirms that the source of the curvature is a tachyon moving with infinite velocity along a straight line, namely the *y*-axis of (83).

**71.3. The *BI*-metric with  $\epsilon_0 = 0$ .** For the choice  $\epsilon_0 = 0$  the *BI*-metric (78) becomes

$$ds^2 = -\frac{p^2}{q^2} dq^2 + p^2 q^2 dt^2 + \left(1 + \frac{2n}{p}\right) dy^2 + \left(1 + \frac{2n}{p}\right)^{-1} dp^2, \quad (84)$$

which is a non-flat generalization of Minkowski metric (53), to which it reduces for  $n \rightarrow 0$ . As can be seen from expressions (54), the singular source at  $p = 0$  is also located at (81), and can again be physically interpreted as a tachyon moving along the *y*-axis.

To summarize: The *BI*-metric for any  $\epsilon_0$  represents a space-time which includes the *gravitational field of a tachyon of ‘strength’  $n$ , moving instantaneously along the straight line given by the *y*-axis*, that is (81), which corresponds to the curvature singularity at  $p = 0$ . It seems that the most natural representation of such solution is given by the metric (83) for the choice  $\epsilon_0 = -1$  because it most naturally covers the axially symmetric region of the space-time (see figures 6 and 7) and avoids the additional singularities associated with the coordinate  $q$ .

**72. The *BII*-metric ( $\epsilon_2 = -1$ )**

In this case in which  $\epsilon_2 = -1$ , it is necessary that  $n > 0$ , and the metric takes the form

$$ds^2 = -p^2(\epsilon_0 + q^2) dt^2 + \frac{p^2}{\epsilon_0 + q^2} dq^2 + \left(\frac{2n}{p} - 1\right) dy^2 + \left(\frac{2n}{p} - 1\right)^{-1} dp^2, \quad (85)$$

with  $p \in (0, 2n)$  and  $q \in (-\infty, \infty)$ , where  $p = 0$  corresponds to a curvature singularity and  $p = 2n$  is some kind of pole. Notice that, significantly, *this metric does not admit a Minkowski limit as  $n \rightarrow 0$*  because this would lead to a wrong signature  $(- + --)$ .

For the choice  $\epsilon_0 = -1$ , the metric becomes

$$ds^2 = -\frac{p^2}{1-q^2} dq^2 + p^2(1-q^2) dt^2 + \left(\frac{2n}{p} - 1\right) dy^2 + \left(\frac{2n}{p} - 1\right)^{-1} dp^2. \quad (86)$$

Again, horizons exist at  $q = \pm 1$ , but now the space-time is time-dependent in the range  $|q| < 1$ , and static elsewhere with temporal coordinate  $t$ . The additional spatial Killing vector is  $\partial_y$ . For the alternative choice  $\epsilon_0 = +1$ , the metric becomes

$$ds^2 = -p^2(1+q^2)dt^2 + \frac{p^2}{1+q^2}dq^2 + \left(\frac{2n}{p} - 1\right)dy^2 + \left(\frac{2n}{p} - 1\right)^{-1}dp^2, \quad (87)$$

which is *globally static everywhere*. The same is true for the choice  $\epsilon_0 = 0$ , with the metric

$$ds^2 = -p^2q^2dt^2 + \frac{p^2}{q^2}dq^2 + \left(\frac{2n}{p} - 1\right)dy^2 + \left(\frac{2n}{p} - 1\right)^{-1}dp^2. \quad (88)$$

The physical meaning of these everywhere curved space-times is, however, unclear since they do not possess the Minkowski limit  $n \rightarrow 0$ .

### 7.3. The BIII-metric ( $\epsilon_2 = 0$ )

This final case of metric (78) occurs when  $\epsilon_2 = 0$ ,

$$ds^2 = -\epsilon_0 p^2 dt^2 + \frac{p^2}{\epsilon_0} dq^2 + \frac{2n}{p} dy^2 + \frac{p}{2n} dp^2. \quad (89)$$

Necessarily  $\epsilon_0 = \pm 1$ , and without loss of generality we may take  $\epsilon_0 = 1$  because the case  $\epsilon_0 = -1$  is equivalent to it via the transformation  $t \leftrightarrow q$ . There is no Minkowski limit  $n \rightarrow 0$ . In this case, it is possible to use a remaining scaling freedom of all coordinates to set  $2n = 1$ , and the metric becomes

$$ds^2 = p^2(-dt^2 + dq^2) + \frac{1}{p} dy^2 + p dp^2, \quad (90)$$

which is everywhere static. Performing a simple transformation

$$p = \sqrt{\rho}, \quad q = C\varphi, \quad (91)$$

we obtain

$$ds^2 = \rho(-dt^2 + C^2 d\varphi^2) + \rho^{-1/2}(\frac{1}{4}d\rho^2 + dy^2). \quad (92)$$

Up to a simple rescaling, this is exactly the *Levi-Civita solution in the limiting case when  $\sigma = 1/4$* , see equations (10.11) and (10.14) in [3]. Interestingly, this is locally isometric to the asymptotic form of the Melvin solution, see (7.21) therein. It can also be expressed in the form (10.8) with the Kasner-like parameters  $(p_0, p_2, p_3) = (\frac{2}{3}, \frac{2}{3}, -\frac{1}{3})$ . This exceptional space-time is also not yet fully understood physically.

## 8. The B-metrics with $\Lambda$ : $n \neq 0$ ( $\gamma, \mathbf{e}, \mathbf{g} = 0$ )

The metric (22) now takes the form

$$ds^2 = -p^2(\epsilon_0 - \epsilon_2 q^2)dt^2 + \frac{p^2}{\epsilon_0 - \epsilon_2 q^2}dq^2 + \left(\epsilon_2 + \frac{2n}{p} - \frac{1}{3}\Lambda p^2\right)dy^2 + \left(\epsilon_2 + \frac{2n}{p} - \frac{1}{3}\Lambda p^2\right)^{-1}dp^2, \quad (93)$$

which clearly reduces to the  $B$ -metric (78) when  $\Lambda = 0$  and to (anti-)de Sitter space in the form (63) when  $n = 0$ .

8.1. The  $BI$ -metric with  $\Lambda$  ( $\epsilon_2 = 1$ )

Preliminary discussion of this class of exact solutions was performed in [11]. It was argued that the  $BI$  metrics can be physically interpreted as the *gravitational field containing a tachyonic source moving (with infinite velocity) in a de Sitter or anti-de Sitter universe*.

Indeed, by inspecting the representation (67) of the de Sitter hyperboloid for the case  $\Lambda > 0$ ,  $\epsilon_2 = 1$ ,  $\epsilon_0 = -1$ , with  $y = a\phi$ , it immediately follows that the singularity  $p = 0$  is located at

$$Z_0 = 0, \quad Z_1 = 0 = Z_2, \quad Z_3 = a \cos \phi, \quad Z_4 = a \sin \phi. \quad (94)$$

In the weak-field limit  $n \rightarrow 0$  this is just the ‘neck’ of the de Sitter hyperboloid (65), and it is a closed circular trajectory of a *spacelike geodesic* corresponding to a tachyon with an infinite velocity. This supports the interpretation of the curved  $BI$ -metric as the *gravitational field generated by a tachyonic source at  $p = 0$  moving instantaneously around the closed de Sitter universe*. In this case it is convenient to put  $q = \sinh \tau$ ,  $t = \varphi \in [0, 2\pi)$ , so that the metric (93) becomes

$$ds^2 = p^2(-d\tau^2 + \cosh^2 \tau d\varphi^2) + (1 + 2n/p - \frac{1}{3}\Lambda p^2) a^2 d\phi^2 + \frac{dp^2}{1 + 2n/p - \frac{1}{3}\Lambda p^2}. \quad (95)$$

This is a type D generalization of the conformally flat de Sitter metric (68). For  $\Lambda = 0$  this reduces to the  $BI$ -metric (83). To maintain the correct signature  $(-+++)$ , the range of  $p$  is finite, namely  $p \in [0, p_{\max})$  such that  $1 + 2n/p_{\max} - \frac{1}{3}\Lambda p_{\max}^2 = 0$ .

A similar interpretation is valid also for  $\Lambda < 0$ . The difference is that, using (74), (75), the singularity  $p = 0$  is now located at

$$Z_0 = 0, \quad Z_1 = 0 = Z_2, \quad Z_3 = \pm a \sinh(y/a), \quad Z_4 = \pm a \cosh(y/a). \quad (96)$$

This is a *main hyperbolic line on the hyperboloid (65) representing the anti-de Sitter universe*. Again, it is spacelike geodesic trajectory of an infinitely fast tachyon moving along a ‘straight line’ in the open hyperbolic universe with  $\Lambda < 0$ . The exact curved solution can be written in the form (95) with  $a\phi$  replaced by  $y \in (-\infty, \infty)$ .

Analogous results could be obtained for other choices of  $\epsilon_0$ , using explicit parameterizations of the de Sitter and anti-de Sitter backgrounds presented in the comprehensive work [11].

8.2. The  $BII$ -metric with  $\Lambda$  ( $\epsilon_2 = -1$ )

This family of metrics reads

$$ds^2 = -p^2(\epsilon_0 + q^2) dt^2 + \frac{p^2}{\epsilon_0 + q^2} dq^2 + \left(\frac{2n}{p} - 1 - \frac{1}{3}\Lambda p^2\right) dy^2 + \left(\frac{2n}{p} - 1 - \frac{1}{3}\Lambda p^2\right)^{-1} dp^2, \quad (97)$$

which clearly reduces to (85) when  $\Lambda = 0$ . The metric (97) only has the required signature for the range of  $p$  for which  $2n - p - \frac{1}{3}\Lambda p^3 > 0$ . Thus, it does not admit an (anti-)de Sitter limit as  $n \rightarrow 0$ . This peculiar family of exact solutions has no obvious physical meaning, unless  $\Lambda < 0$  with  $|\Lambda|$  large enough, in which case for  $n = 0$  we obtain the anti-de Sitter background (76).

8.3. The Brill-metric with  $\Lambda$  ( $\epsilon_2 = 0$ )

In this last case the metric (93) reduces to (without loss of generality we may set  $\epsilon_0 = 1$ )

$$ds^2 = p^2(-dt^2 + dq^2) + \left(\frac{2n}{p} - \frac{1}{3}\Lambda p^2\right) dy^2 + \left(\frac{2n}{p} - \frac{1}{3}\Lambda p^2\right)^{-1} dp^2, \quad (98)$$

generalizing (89).

For  $\Lambda > 0, n > 0$  it is possible to apply the transformation

$$p = \left(\frac{6n}{\Lambda} \sin^2 \frac{\sqrt{3\Lambda}}{2} \rho\right)^{\frac{1}{3}}, \quad y = B \left(\frac{3}{4n}\right)^{\frac{1}{3}} \varphi, \quad t = \left(\frac{2}{9n}\right)^{\frac{1}{3}} \tilde{t}, \quad q = C \left(\frac{2}{9n}\right)^{\frac{1}{3}} \tilde{y}, \quad (99)$$

obtaining

$$ds^2 = \left(\frac{4}{3\Lambda} \sin^2 \frac{\sqrt{3\Lambda}}{2} \rho\right)^{\frac{2}{3}} (-d\tilde{t}^2 + C^2 d\tilde{y}^2) + B^2 \left(\frac{\sqrt{3\Lambda} \cos^3 \frac{\sqrt{3\Lambda}}{2} \rho}{2 \sin \frac{\sqrt{3\Lambda}}{2} \rho}\right)^{\frac{2}{3}} d\varphi^2 + d\rho^2. \quad (100)$$

This is the *Linet–Tian metric*

$$ds^2 = Q^{2/3} \left( -P^{-2(1-8\sigma+4\sigma^2)/3\Sigma} d\tilde{t}^2 + B^2 P^{-2(1+4\sigma-8\sigma^2)/3\Sigma} d\varphi^2 + C^2 P^{4(1-2\sigma-2\sigma^2)/3\Sigma} d\tilde{y}^2 \right) + d\rho^2, \quad (101)$$

where

$$Q(\rho) = \frac{1}{\sqrt{3\Lambda}} \sin(\sqrt{3\Lambda} \rho), \quad P(\rho) = \frac{2}{\sqrt{3\Lambda}} \tan\left(\frac{\sqrt{3\Lambda}}{2} \rho\right), \quad (102)$$

see [15, 16] and [17], in the case  $\sigma = 1/4$  ( $B$  and  $C$  are conicity parameters). The Linet–Tian metric is a generalization of the Levi-Civita metric to  $\Lambda \neq 0$ . It is a *static, cylindrically symmetric vacuum metric*. The parameter  $\sigma$  can be interpreted as the mass density of the source along the axis  $\rho = 0$ .

Alternatively, we can also perform the transformation

$$p = \left(\frac{6n}{\Lambda} \cos^2 \frac{\sqrt{3\Lambda}}{2} \rho\right)^{\frac{1}{3}}, \quad y = C \left(\frac{4}{3n\Lambda^2}\right)^{\frac{1}{3}} \tilde{y}, \quad t = \left(\frac{\Lambda}{6n}\right)^{\frac{1}{3}} \tilde{t}, \quad q = B \left(\frac{\Lambda}{6n}\right)^{\frac{1}{3}} \varphi, \quad (103)$$

leading to

$$ds^2 = \cos^{\frac{4}{3}} \frac{\sqrt{3\Lambda}}{2} \rho (-d\tilde{t}^2 + B^2 d\varphi^2) + \frac{4}{3\Lambda} \left(\frac{\sin^3 \frac{\sqrt{3\Lambda}}{2} \rho}{\cos \frac{\sqrt{3\Lambda}}{2} \rho}\right)^{\frac{2}{3}} C^2 d\tilde{y}^2 + d\rho^2, \quad (104)$$

which is again the metric (101) but now for  $\sigma = 0$ .

In fact, general Linet–Tian metric for  $\Lambda > 0$  is invariant with respect to a ‘duality’

$$\begin{aligned} \rho &= \frac{\pi}{\sqrt{3\Lambda}} - \rho', & t &= \left(\frac{4}{3\Lambda}\right)^{(1-8\sigma+4\sigma^2)/\Sigma} t', \\ Cy &= \left(\frac{4}{3\Lambda}\right)^{-2(1-2\sigma-2\sigma^2)/3\Sigma} B' \varphi', & B\varphi &= \left(\frac{4}{3\Lambda}\right)^{(1+4\sigma-8\sigma^2)/3\Sigma} C' y', \end{aligned} \quad (105)$$

resulting in

$$\sigma = \frac{1 - 4\sigma'}{4(1 - \sigma')}. \tag{106}$$

For the special choice  $n = \frac{1}{6}\Lambda$  this relation between the *BIII*-metric and the Linet–Tian metric can be found in [17], but it is clear from (103) that this transformation exists for any  $n > 0$ . Contrary to the Levi-Civita metric, the Linet–Tian metric does not give the conformally flat solution when  $\sigma = 0$ .

Similar relations apply to  $\Lambda < 0$  with the difference that, instead of (102), the functions  $P$  and  $Q$  are now

$$Q(\rho) = \frac{1}{\sqrt{3|\Lambda|}} \sinh\left(\sqrt{3|\Lambda|}\rho\right), \quad P(\rho) = \frac{2}{\sqrt{3|\Lambda|}} \tanh\left(\frac{\sqrt{3|\Lambda|}}{2}\rho\right). \tag{107}$$

For  $\Lambda < 0, n > 0$  the transformation is (99) with

$$p = \left(\frac{6n}{|\Lambda|} \sinh^2 \frac{\sqrt{3|\Lambda|}}{2}\rho\right)^{\frac{1}{3}}, \tag{108}$$

yielding the Linet–Tian metric (101) for  $\sigma = 1/4$ :

$$ds^2 = \left(\frac{4}{3|\Lambda|} \sinh^2 \frac{\sqrt{3|\Lambda|}}{2}\rho\right)^{\frac{2}{3}} (-d\tilde{r}^2 + C^2 dy^2) + B^2 \left(\frac{\sqrt{3|\Lambda|}}{2} \frac{\cosh^3 \frac{\sqrt{3|\Lambda|}}{2}\rho}{\sinh \frac{\sqrt{3|\Lambda|}}{2}\rho}\right)^{\frac{2}{3}} d\varphi^2 + d\rho^2. \tag{109}$$

For  $\Lambda < 0, n < 0$  the transformation is (103) with

$$p = \left(\frac{6n}{\Lambda} \cosh^2 \frac{\sqrt{3|\Lambda|}}{2}\rho\right)^{\frac{1}{3}}, \tag{110}$$

yielding the Linet–Tian metric for  $\sigma = 0$ :

$$ds^2 = \cosh^{\frac{4}{3}} \frac{\sqrt{3|\Lambda|}}{2}\rho (-d\tilde{r}^2 + B^2 d\varphi^2) + \frac{4}{3|\Lambda|} \left(\frac{\sinh^3 \frac{\sqrt{3|\Lambda|}}{2}\rho}{\cosh \frac{\sqrt{3|\Lambda|}}{2}\rho}\right)^{\frac{2}{3}} C^2 dy^2 + d\rho^2. \tag{111}$$

We thus conclude that the *BIII*-metrics with  $\Lambda$  are fully equivalent to the Linet–Tian family of static, cylindrically symmetric metrics with the special value of  $\sigma = 1/4$ , which is dual to  $\sigma = 0$ .

### 9. General vacuum case with $\gamma \neq 0$ ( $\mathbf{e}, \mathbf{g} = 0$ )

Let us now analyze the *most general vacuum metric of the non-expanding Plebański–Demiański class* with any cosmological constant  $\Lambda$ . This is easily obtained from (22), (23) by setting  $e = 0 = g$ , in which case the electromagnetic field vanishes:

$$ds^2 = \varrho^2 \left(-Q dt^2 + \frac{1}{Q} dq^2\right) + \frac{\mathcal{P}}{\varrho^2} \left(dy + 2\gamma q dt\right)^2 + \frac{\varrho^2}{\mathcal{P}} dp^2, \tag{112}$$

where

$$\begin{aligned} g^2 &= p^2 + \gamma^2, \\ \mathcal{Q}(q) &= \epsilon_0 - \epsilon_2 q^2, \\ \mathcal{P}(p) &= \gamma^2(-\epsilon_2 + \Lambda\gamma^2) + 2np + (\epsilon_2 - 2\Lambda\gamma^2)p^2 - \frac{1}{3}\Lambda p^4. \end{aligned} \quad (113)$$

This is a generalization of the  $B$ -metrics (discussed in previous sections) to include an *additional parameter*  $\gamma$ .

To clarify the geometrical and physical meaning of this parameter  $\gamma$  we first observe that the corresponding Weyl curvature scalar (24) reduces to

$$\Psi_2 = \frac{\gamma(\epsilon_2 - \frac{4}{3}\Lambda\gamma^2) - in}{(\gamma + ip)^3}. \quad (114)$$

Therefore, the space-times with  $\gamma \neq 0$  are of *algebraic type D* and contain *no curvature singularity*.

The only possible exception is

$$n = 0, \quad \frac{4}{3}\Lambda\gamma^2 = \epsilon_2,$$

in which case the space-time is *conformally flat*, with  $\mathcal{P} = -\frac{1}{3}\Lambda(p^2 + \gamma^2)^2$ , that is

$$ds^2 = (p^2 + \gamma^2) \left( -(\epsilon_0 - \epsilon_2 q^2) dt^2 + \frac{dq^2}{\epsilon_0 - \epsilon_2 q^2} \right) - \frac{1}{3}\Lambda(p^2 + \gamma^2)(dy + 2\gamma q dt)^2 - \frac{dp^2}{\frac{1}{3}\Lambda(p^2 + \gamma^2)}. \quad (115)$$

Clearly,  $\Lambda \geq 0$  is prohibited since this would lead to a degenerate metric or wrong signature. The only possibility is  $\Lambda < 0$ , implying  $\epsilon_2 = -1$  and  $\gamma^2 = \frac{1}{4}a^2$ , where  $a = \sqrt{3/|\Lambda|}$  as in (65). Being conformally flat and vacuum, such a metric

$$ds^2 = (p^2 + \frac{1}{4}a^2) \left( \frac{dq^2}{\epsilon_0 + q^2} - \epsilon_0 dt^2 + 2a^{-1}q dt dy + a^{-2}dy^2 \right) + \frac{a^2 dp^2}{p^2 + \frac{1}{4}a^2} \quad (116)$$

must be an *unfamiliar metric form of the anti-de Sitter space*. Indeed, it is possible to remove the non-diagonal term  $dt dy$  by performing a linear transformation

$$t = b_1 y' + b_2 t', \quad y = c_1 y' + c_2 t', \quad (117)$$

where

$$c_1 = \sqrt{-\epsilon_0} a b_1, \quad c_2 = -\sqrt{-\epsilon_0} a b_2, \quad (118)$$

resulting in

$$ds^2 = (p^2 + \frac{1}{4}a^2) \left( \frac{dq^2}{\epsilon_0 + q^2} + 2(-\epsilon_0 + \sqrt{-\epsilon_0} q) b_1^2 dy'^2 + 2(-\epsilon_0 - \sqrt{-\epsilon_0} q) b_2^2 dt'^2 \right) + \frac{a^2 dp^2}{p^2 + \frac{1}{4}a^2}. \quad (119)$$

For  $\epsilon_0 = -1$  we choose  $b_1 = 1 = b_2$ , implying  $c_1 = a = -c_2$ , and the metric becomes

$$ds^2 = (4p^2 + a^2) \left( -\frac{\frac{1}{4}dq^2}{1 - q^2} + \frac{1 + q}{2} dy'^2 + \frac{1 - q}{2} dt'^2 \right) + \frac{4a^2 dp^2}{4p^2 + a^2}. \quad (120)$$

When  $q < 1$ , a further transformation

$$2p = a \sinh \theta, \quad q = \cos 2\chi, \quad (121)$$

leads to

$$ds^2 = a^2 \cosh^2 \theta (-d\chi^2 + \cos^2 \chi dy'^2 + \sin^2 \chi dt'^2) + a^2 d\theta^2. \quad (122)$$

This is an interesting *new diagonal metric form of the anti-de Sitter space* corresponding to the parametrization

$$\left. \begin{aligned} Z_0 &= a \cosh \theta \cos \chi \cosh y', \\ Z_1 &= a \cosh \theta \cos \chi \sinh y', \\ Z_2 &= a \sinh \theta, \\ Z_3 &= a \cosh \theta \sin \chi \sinh t', \\ Z_4 &= a \cosh \theta \sin \chi \cosh t', \end{aligned} \right\} \Rightarrow \begin{cases} \tanh y' = \frac{Z_1}{Z_0}, \\ \tanh t' = \frac{Z_3}{Z_4}, \\ a \sinh \theta = 2p = Z_2, \\ \tan \chi = \sqrt{\frac{Z_4^2 - Z_3^2}{Z_0^2 - Z_1^2}}, \end{cases} \quad (123)$$

of the hyperboloid (66).

When  $q > 1$ , an analogous transformation

$$2p = a \sinh \theta, \quad q = \cosh 2\chi, \quad (124)$$

puts (120) to *another* metric form of the anti-de Sitter space

$$ds^2 = a^2 \cosh^2 \theta (d\chi^2 + \cosh^2 \chi dy'^2 - \sinh^2 \chi dt'^2) + a^2 d\theta^2, \quad (125)$$

corresponding to

$$\left. \begin{aligned} Z_0 &= a \cosh \theta \cosh \chi \cosh y', \\ Z_1 &= a \cosh \theta \cosh \chi \sinh y', \\ Z_2 &= a \sinh \theta, \\ Z_3 &= a \cosh \theta \sinh \chi \cosh t', \\ Z_4 &= a \cosh \theta \sinh \chi \sinh t', \end{aligned} \right\} \Rightarrow \begin{cases} \tanh y' = \frac{Z_1}{Z_0}, \\ \tanh t' = \frac{Z_4}{Z_3}, \\ a \sinh \theta = 2p = Z_2, \\ \tanh \chi = \sqrt{\frac{Z_3^2 - Z_4^2}{Z_0^2 - Z_1^2}}. \end{cases} \quad (126)$$

In the case when  $\epsilon_0 = 1$  we choose  $b_1 = i = b_2$ , thus  $c_2 = a = -c_1$ , and with the reparametrization  $q \rightarrow iq$  the real metric becomes exactly the same as (120).

Returning now to type D space-times (112), (113) with  $\gamma \neq 0$ , it follows from (114) that *they are all non-singular* and the range of  $p$  can be  $(-\infty, +\infty)$ . Indeed, the curvature singularity at  $p = 0$ , which is always present when  $\gamma = 0$  (that is for the *B*-metrics described in previous section, see (79)), is not reached since the denominator  $\gamma + ip$  in (114) now has a *finite non-zero value*  $\gamma$  for  $p = 0$ . Therefore, the privileged value  $p = 0$  does not correspond to a physical singularity, but rather to a *region of space-time with a maximum finite curvature* because  $\Psi_2$  has the greatest value there.

Such a behavior is analogous to the more familiar situation known for the *A*-metrics, in particular for the Schwarzschild solution with the mass parameter  $m$ . By adding the parameter  $l$  in the Taub-NUT solution, the curvature singularity at  $r = 0$  is removed, see e.g. chapter 12 in [3]. Similarly, by adding the parameter  $\gamma$  to the *B*-metrics with a ‘tachyonic mass’ parameter

$n$ , the curvature singularity at  $p = 0$  is also removed. This formal analogy was noticed already by Plebański in 1975 [6] and, because of it, he denoted this class with  $\gamma \neq 0$  as the so called ‘anti-NUT solution’.

However, it should be noted that there are also some fundamental geometrical differences between the  $A$ -metrics and  $B$ -metrics case. While for the Taub-NUT solution with the parameter  $l$  the double degenerate principal null directions  $\mathbf{k}$  and  $\mathbf{l}$  are expanding and twisting, for the  $B$ -metrics with the parameter  $\gamma$  they are non-expanding and non-twisting (in fact, the whole family of solutions belongs to the Kundt class).

Although there is no curvature singularity at  $p = 0$  when  $\gamma \neq 0$ , and *asymptotically the space-times contain conformally flat regions as  $p \rightarrow \pm\infty$* , see (114) implying  $\Psi_2 \rightarrow 0$ , in general there are *Killing horizons* associated with the vector field  $\partial_t$ . They separate stationary regions from the dynamical one. Indeed, it follows from the metric form (112) that the norm of this vector is

$$\|\partial_t\|^2 = g_{tt} = -\varrho^2 \mathcal{Q} + 4\gamma^2 q^2 \frac{\mathcal{P}}{\varrho^2}, \quad (127)$$

where  $\mathcal{Q}$  and  $\mathcal{P}$  are given by (113). The associated Killing horizon is thus located at

$$(p^2 + \gamma^2)^2 \mathcal{Q} = 4\gamma^2 q^2 \mathcal{P}. \quad (128)$$

This is rather complicated expression, polynomial in the coordinates  $q$  and  $p$ , and also depending on all five geometrical and physical parameters. Interestingly, in the case  $\gamma = 0$  it simplifies enormously to the condition  $\mathcal{Q} = 0$ , so that the Killing horizon is simply located at  $q^2 = \epsilon_0/\epsilon_2$ . This is basically the same condition as for the Minkowski and (anti-)de Sitter backgrounds discussed in previous sections 5 and 6, respectively, or in [11].

To maintain the correct signature of the metric (112), the function  $\mathcal{P}(p)$  must be *positive*. The allowed range of  $p$  is thus constrained. In particular, for  $n = 0 = \Lambda$  such a constraint reads  $\mathcal{P} = \epsilon_2 (p^2 - \gamma^2) > 0$ , i.e. the boundary values are  $p = \pm\gamma$ , and  $\epsilon_2 = 0$  is forbidden.

A deeper understanding of the physical meaning of the parameter  $\gamma$ , such as its influence on particle motion or on the global structure, is left for future work.

## 10. Charged metrics: the most general case with $\mathbf{e}, \mathbf{g} \neq \mathbf{0}$

It remains to analyze the complete non-expanding Plebański–Demiański metric (22), (23), i.e.

$$ds^2 = (p^2 + \gamma^2) \left( -(\epsilon_0 - \epsilon_2 q^2) dt^2 + \frac{dq^2}{\epsilon_0 - \epsilon_2 q^2} \right) + \mathcal{R} (dy + 2\gamma q dt)^2 + \frac{1}{\mathcal{R}} dp^2, \quad (129)$$

where

$$\mathcal{R}(p) = \frac{-(e^2 + g^2) - \epsilon_2 \gamma^2 + \Lambda \gamma^4 + 2np + (\epsilon_2 - 2\Lambda \gamma^2)p^2 - \frac{1}{3}\Lambda p^4}{p^2 + \gamma^2}. \quad (130)$$

It contains seven free parameters, namely two discrete geometric parameters  $\epsilon_0, \epsilon_2$  and five physical parameters  $\Lambda, n, \gamma$ , plus  $e$  and  $g$ . When  $e = 0 = g$  the space-times are vacuum, as described in previous sections. For non-vanishing  $e, g$  the Ricci scalar  $\Phi_{11}$  is non-zero, see (24), and *such exact space-times contain a non-null electromagnetic field* (the source-free Maxwell equations are also satisfied) which is doubly aligned with the repeated null directions of the gravitational field. In fact, they can be understood as a large class of  $B$ -metrics with the



‘mass’ parameter  $n$ , generalized to admit electric and magnetic charges  $e, g$ , in addition to the cosmological constant  $\Lambda$ . As can be seen from (24), with a non-trivial parameter  $\gamma$ , both the gravitational and the electromagnetic fields are non-singular.

Let us also note that the parameter  $\epsilon_0$  is not physically important. It only distinguishes three coordinate representations of the 2-space of constant curvature (given by  $\epsilon_2$ ) spanned by the coordinates  $t$  and  $q$ . For example, explicit transformation from the metric (129) with  $\epsilon_2 = -1$ ,  $\epsilon_0 = 1$  (with coordinates relabeled to  $\tilde{t}, \tilde{q}, \tilde{y}, |\tilde{q}| < 1$ ) to the metric with  $\epsilon_0 = -1$  is

$$\tan \tilde{t} = \frac{-q}{\sqrt{1-q^2} \cosh t}, \quad \tilde{q} = \sqrt{1-q^2} \sinh t, \quad \tilde{y} = y + 2\gamma \arg \tanh(q \tanh t). \quad (131)$$

Moreover, as shown explicitly for the case  $\epsilon_2 = -1$ ,  $\epsilon_0 = -1$  in section 9, the off-diagonal term  $dy dt$  in such a form of the anti-de Sitter background can be completely removed. Similar arguments also apply to the case  $\epsilon_0 = 0$ .

### 10.1. The case when $\gamma = 0$ : Charged B-metrics with $\Lambda$

With  $\gamma = 0$ , the metric (129), (130) simplifies considerably to

$$ds^2 = -p^2(\epsilon_0 - \epsilon_2 q^2) dt^2 + \frac{p^2}{\epsilon_0 - \epsilon_2 q^2} dq^2 + \mathcal{R} dy^2 + \frac{1}{\mathcal{R}} dp^2, \quad (132)$$

where

$$\mathcal{R}(p) = \epsilon_2 + \frac{2n}{p} - \frac{e^2 + g^2}{p^2} - \frac{\Lambda}{3} p^2. \quad (133)$$

The metric functions are now given in terms of two geometrical parameters  $\epsilon_0, \epsilon_2 = +1, 0, -1$ , one ‘mass’ parameter  $n$ , the electric/magnetic charge parameters  $e$  and  $g$ , and the cosmological constant  $\Lambda$ . The non-zero curvature scalars are  $R = 4\Lambda$  and

$$\Psi_2 = \frac{n}{p^3} - \frac{e^2 + g^2}{p^4}, \quad \Phi_{11} = \frac{e^2 + g^2}{2p^4}. \quad (134)$$

Together these clearly indicate the presence of a *curvature singularity at  $p = 0$*  whenever either  $n$  or  $e^2 + g^2$  are non-zero. Moreover, its ‘strength’ is directly proportional to these parameters. Such solutions represent a generalization of the B-metrics (78), as originally described by Ehlers and Kundt [12], to include charges and a cosmological constant.

### 10.2. The electromagnetic field

Finally, we will investigate the electromagnetic field associated with the general space-time (129), (130). It is described by antisymmetric Faraday–Maxwell tensor  $F_{\mu\nu}$ , or the related 2-form

$$F = \frac{1}{2} F_{\mu\nu} dx^\mu \wedge dx^\nu. \quad (135)$$

Its dual is  $\tilde{F}_{\mu\nu} \equiv \frac{1}{2} \varepsilon_{\mu\nu\alpha\beta} F^{\alpha\beta}$ , where  $\varepsilon_{0123} = \sqrt{-g}$ . Maxwell’s equations without sources are  $F^{\mu\nu}{}_{;\nu} = 0$ ,  $\tilde{F}^{\mu\nu}{}_{;\nu} = 0$ , which can be rewritten as  $d\Omega = 0$ , where the complex 2-form  $\Omega$  is defined by  $\Omega \equiv F + i\tilde{F} = \frac{1}{2}(F_{\mu\nu} + i\tilde{F}_{\mu\nu}) dx^\mu \wedge dx^\nu$ .

Non-trivial components of the electromagnetic field associated with (129), (130) are

$$\begin{aligned}
F_{qt} &= -\frac{e(\gamma^2 - p^2) + 2g\gamma p}{\gamma^2 + p^2}, \\
F_{yp} &= \frac{g(\gamma^2 - p^2) - 2e\gamma p}{(\gamma^2 + p^2)^2}, \\
F_{pt} &= -2\gamma q \frac{g(\gamma^2 - p^2) - 2e\gamma p}{(\gamma^2 + p^2)^2},
\end{aligned} \tag{136}$$

and for the dual

$$\begin{aligned}
\tilde{F}_{qt} &= -\frac{g(\gamma^2 - p^2) - 2e\gamma p}{\gamma^2 + p^2}, \\
\tilde{F}_{yp} &= -\frac{e(\gamma^2 - p^2) + 2g\gamma p}{(\gamma^2 + p^2)^2}, \\
\tilde{F}_{pt} &= 2\gamma q \frac{e(\gamma^2 - p^2) + 2g\gamma p}{(\gamma^2 + p^2)^2},
\end{aligned} \tag{137}$$

see [18] for more details. These expressions simplify considerably when  $\gamma = 0$  to

$$\begin{aligned}
F_{qt} &= e, & F_{yp} &= -gp^{-2}, \\
\tilde{F}_{qt} &= g, & \tilde{F}_{yp} &= +ep^{-2}.
\end{aligned} \tag{138}$$

The dual  $\tilde{F}$  is obviously obtained from  $F$  just by interchanging  $e \rightarrow g$ ,  $g \rightarrow -e$ , i.e. there is a duality between the *electric charge*  $e$  and the *magnetic charge*  $g$ . Such electromagnetic fields *diverge at*  $p = 0$ , i.e. at the singularity of the gravitational field given by the  $B$ -metrics (78), (93). In this case

$$\Omega = (e + ig) d(q dt + ip^{-1} dy) = (e + ig) (dq \wedge dt + ip^{-2} dy \wedge dp), \tag{139}$$

and the corresponding 4-potential  $A = A_\mu dx^\mu$ , such that  $F = dA$ , has a very simple form

$$A = e q dt - gp^{-1} dy. \tag{140}$$

Returning now to the most general case with  $\gamma$ , we can express the general electromagnetic field (136) with respect to the null tetrad (13) where now  $\alpha = 0$ ,  $\omega = 1$ . In the *NP formalism* this is given by three complex functions  $\Phi_A$  defined as

$$\Phi_0 = F_{\mu\nu} k^\mu m^\nu, \quad \Phi_1 = \frac{1}{2} F_{\mu\nu} (k^\mu l^\nu + \bar{m}^\mu m^\nu), \quad \Phi_2 = F_{\mu\nu} \bar{m}^\mu l^\nu. \tag{141}$$

They take the form

$$\Phi_1 = -\frac{e + ig}{2(\gamma + ip)^2}, \quad \Phi_0 = 0 = \Phi_2, \tag{142}$$

corresponding to the only non-vanishing tetrad components

$$F_{kl} \equiv F_{\mu\nu} k^\mu l^\nu = -\frac{e(\gamma^2 - p^2) + 2g\gamma p}{(\gamma^2 + p^2)^2}, \quad F_{\bar{m}m} \equiv F_{\mu\nu} \bar{m}^\mu m^\nu = -i \frac{g(\gamma^2 - p^2) - 2e\gamma p}{(\gamma^2 + p^2)^2}. \tag{143}$$

Since the related *Ricci tensor* in the NP formalism is  $\Phi_{AB} = 2\Phi_A \bar{\Phi}_B$  the only non-vanishing component is

$$\Phi_{11} = \frac{e^2 + g^2}{2(p^2 + \gamma^2)^2}, \tag{144}$$

which is fully consistent with (24).

Finally, a complex invariant of the electromagnetic field reads

$$\frac{1}{8} (F_{\mu\nu} F^{\mu\nu} + i F_{\mu\nu} \tilde{F}^{\mu\nu}) \equiv \Phi_0 \Phi_2 - (\Phi_1)^2 = -\frac{1}{4} \frac{(e + i g)^2}{(\gamma + i p)^4}. \quad (145)$$

It is non-zero, so that the electromagnetic field is non-radiating (non-null). Indeed, (since only  $\Phi_1 \neq 0$ ) it is of a general algebraic type with the null vectors  $\mathbf{k}$  and  $\mathbf{l}$  of the electromagnetic field aligned with the double degenerate principal null directions of the Weyl tensor representing type D gravitational field.

Moreover, it can be seen from (145) that for  $\gamma \neq 0$  the electromagnetic field is everywhere finite, and for  $p \rightarrow \infty$  the field vanishes asymptotically. Only for the family of  $B$ -metrics (if, and only if,  $\gamma = 0$ ) there is a singularity located at  $p = 0$ .

## 11. Summary and conclusions

We have here presented and analyzed the complete family of non-expanding Plebański–Demiański space-times which are (electro)vacuum solutions with any cosmological constant of algebraic type D. Such a family can be explicitly obtained by performing a specific limit (section 1) leading to a vanishing expansion, twist and shear, i.e. to the Kundt class (section 3). By demonstrating (section 2) that the parameter  $\alpha$ , originally representing acceleration, can always be removed, and  $\omega$  set to 1, we proved that all such solutions can be written in the metric form (22), (23). The only exception is the family of direct-product geometries that is obtained by another limit when  $\alpha = 0 = \omega$  (section 4).

This class of solutions contains two discrete parameters  $\epsilon_0, \epsilon_2 = +1, 0, -1$  and five continuous parameters  $n, \gamma$  and  $e, g, \Lambda$ . In our contribution we thoroughly investigated the geometrical and physical meanings of all these parameters, and we have provided basic interpretations of the corresponding space-times.

First, in section 5 we determined the geometrical meaning of  $\epsilon_0$  and  $\epsilon_2$  in the case when all other parameters are set to zero. We showed that these discrete parameters correspond to specific new coordinate representations of certain regions of the background Minkowski space. In the presence of a cosmological constant  $\Lambda \neq 0$  the parameters  $\epsilon_0$  and  $\epsilon_2$  analogously determine specific coordinate representations of the de Sitter or anti-de Sitter backgrounds, see section 6 and our previous work [11].

The physical meaning of the parameter  $n$  was elucidated in section 7. Its presence defines the family of  $B$ -metrics, with a curvature singularity at  $p = 0$ . In particular, the  $BI$ -metric defined by  $\epsilon_2 = 1$  represents an exact gravitational field of a tachyon of ‘mass’  $n$ , moving with an infinite velocity along a straight line. The same physical interpretation can be given to the  $B$ -metrics with  $\Lambda$ , in which case the tachyonic source moves in the (anti-)de Sitter universe, see section 8. On the other hand, the  $BIII$ -metrics are special cases of the Levi-Civita and Linet–Tian metrics for which  $\sigma = 1/4$ , or its dual  $\sigma = 0$ .

The meaning of the parameter  $\gamma$  was identified in section 9 as a formal analogue of the NUT parameter. Its presence in the most general vacuum metric (112), (113) of the non-expanding Plebański–Demiański class (which contains the parameters  $\epsilon_0, \epsilon_2, \Lambda, n, \gamma$ ) causes the curvature singularity of the generalized  $B$ -metrics to be removed. As a by-product we also found two completely new diagonal metric forms of the anti-de Sitter space, namely (122) and (125).

Finally, as shown in section 10, the additional two parameters  $e$  and  $g$  denote electric and magnetic charge parameters, respectively. The corresponding space-times (129), (130) of ‘charged  $B$ -metrics with  $\Lambda$  and  $\gamma$ ’ contain a specific (source-free) electromagnetic field. We

presented the explicit form of this non-null Maxwell field (136), (137), and we described its properties.

We hope that this clarification of all the parameters of the full family of non-expanding Plebański–Demiański (electro)vacuum solutions will help in finding useful applications of this large and interesting class of exact space-times.

## Acknowledgments

This work was supported by the Czech Science Foundation grant GAČR 17-01625S. OH also acknowledges the support by the Charles University Grant GAUK 196516. We are grateful to Robert Švarc for reading the manuscript and some useful suggestions.

## ORCID iDs

J Podolský  <https://orcid.org/0000-0003-2998-6830>

O Hruška  <https://orcid.org/0000-0003-1022-7949>

J B Griffiths  <https://orcid.org/0000-0002-7335-5561>

## References

- [1] Plebański J F and Demiański M 1976 Rotating charged and uniformly accelerating mass in general relativity *Ann. Phys.* **98** 98–127
- [2] Griffiths J B and Podolský J 2006 A new look at the Plebański–Demiański family of solutions *Int. J. Mod. Phys. D* **15** 335–69
- [3] Griffiths J B and Podolský J 2009 *Exact Space-Times in Einstein’s General Relativity* (Cambridge: Cambridge University Press)
- [4] Griffiths J B and Podolský J 2005 Accelerating and rotating black holes *Class. Quantum Grav.* **22** 3467–79
- [5] Carter B 1968 Hamilton–Jacobi and Schrödinger separable solutions of Einstein’s equations *Commun. Math. Phys.* **10** 280–310
- [6] Plebański J F 1975 A class of solutions of the Einstein–Maxwell equations *Ann. Phys.* **90** 196–255
- [7] Plebański J F 1979 The nondiverging and nontwisting type D electrovac solutions with  $\lambda$  *J. Math. Phys.* **20** 1946–62
- [8] García Díaz A and Plebański J F 1982 Solutions of type D possessing a group with null orbits as contractions of the seven-parameter solution *J. Math. Phys.* **23** 1463–5
- [9] Kinnersley W 1969 Type D vacuum metrics *J. Math. Phys.* **10** 1195–203
- [10] Van den Bergh N 2017 Algebraically special Einstein–Maxwell fields *Gen. Relativ. Gravit.* **49** 9
- [11] Podolský J and Hruška O 2017 Yet another family of diagonal metrics for de Sitter and anti-de Sitter spacetimes *Phys. Rev. D* **95** 124052
- [12] Ehlers J and Kundt W 1962 Exact solutions of the gravitational field equations *Gravitation: an Introduction to Current Research* (New York: Wiley) pp 49–101
- [13] Martins A P M 1996 The sources of the A and B degenerate static vacuum fields *Gen. Relativ. Gravit.* **28** 1309–20
- [14] Gott J R 1974 Tachyon singularity: a spacelike counterpart of the Schwarzschild black hole *Nuovo Cimento B* **22** 49–69
- [15] Linet B 1986 The static, cylindrically symmetric strings in general relativity with cosmological constant *J. Math. Phys.* **27** 1817–8
- [16] Tian Q 1986 Cosmic strings with cosmological constant *Phys. Rev. D* **33** 3549–55
- [17] Griffiths J B and Podolský J 2010 The Linet–Tian solution with a positive cosmological constant in four and higher dimensions *Phys. Rev. D* **81** 064015
- [18] Hruška O 2015 The study of exact spacetimes with a cosmological constant *Diploma Thesis* Charles University, Faculty of Mathematics and Physics, Prague 193 p